

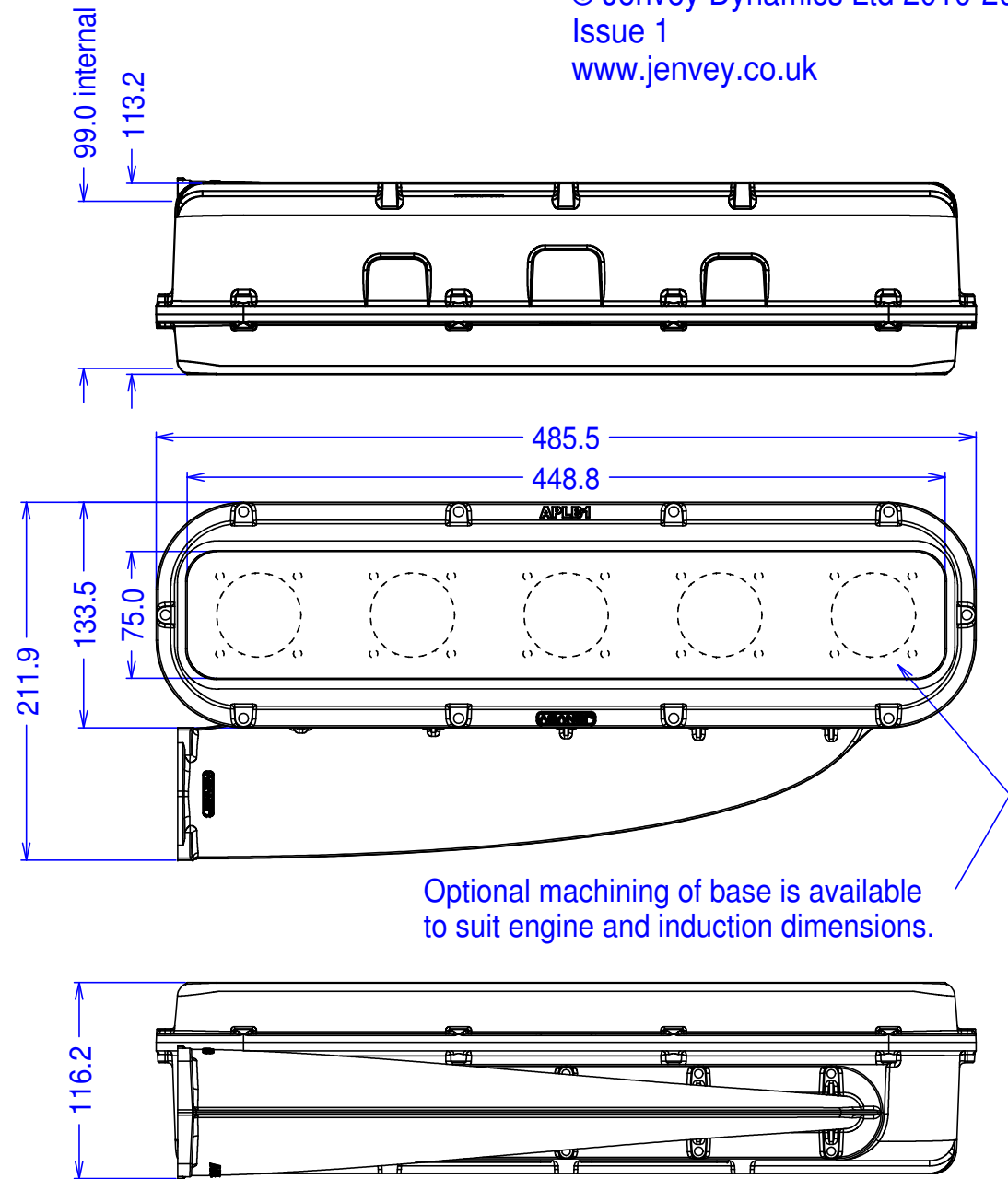

APLC-70 Long Plenum for pressure-charged engines

Diffuser shape and dimensions are proportioned appropriately to suit the flow of 70mm inlet size and encourages even air distribution to all cylinders.

Cover face accepts injectors and fuel rail mountings

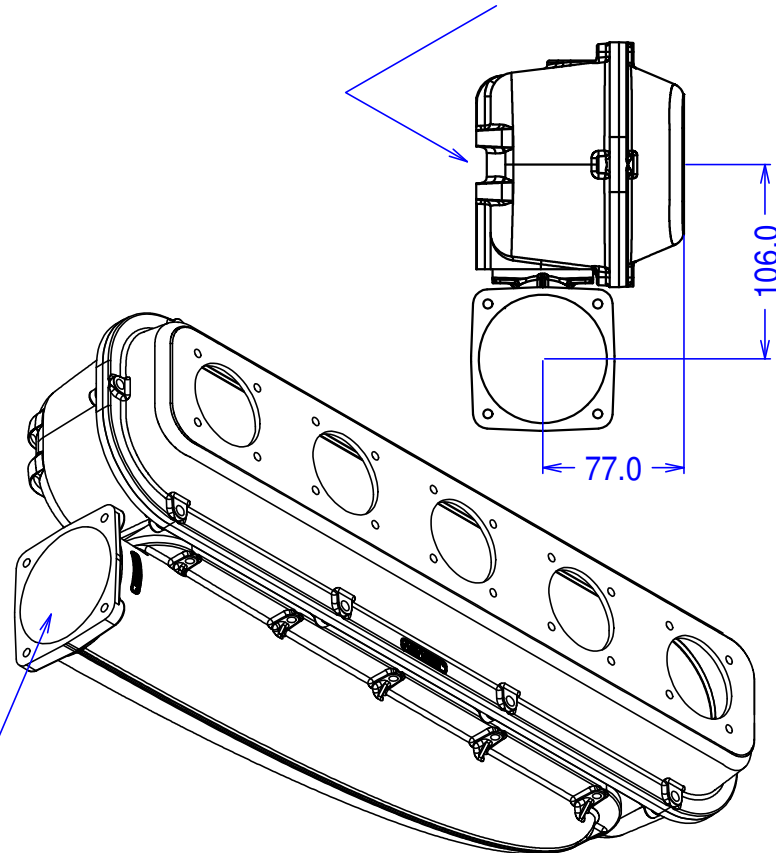

Optional machining of base is available to suit engine and induction dimensions.

Diffuser may be fitted above or below the plenum and pointing to left or right.