

CKB03-TD - BMW M10 - HERITAGE KIT

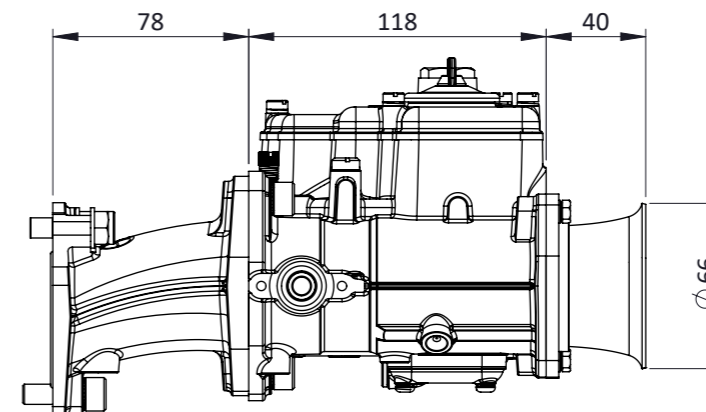

Engineered to win

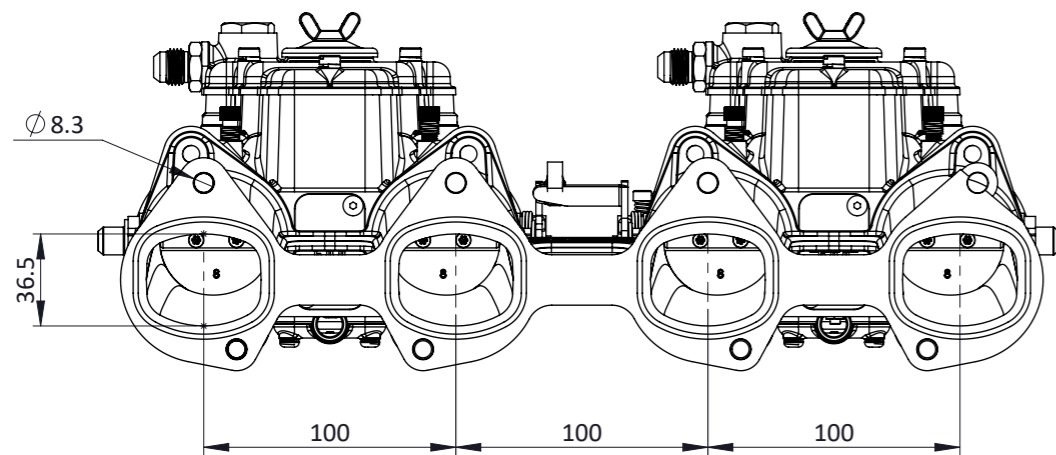
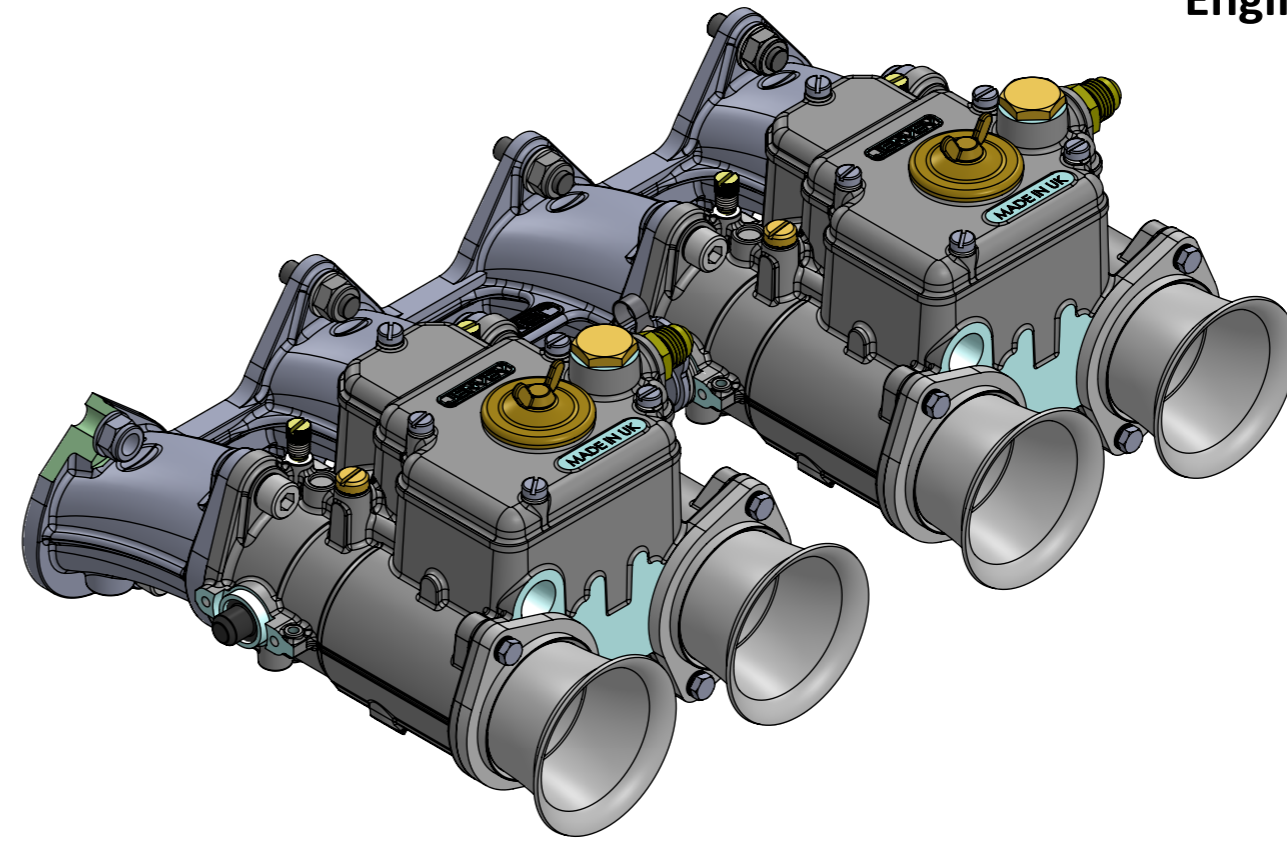
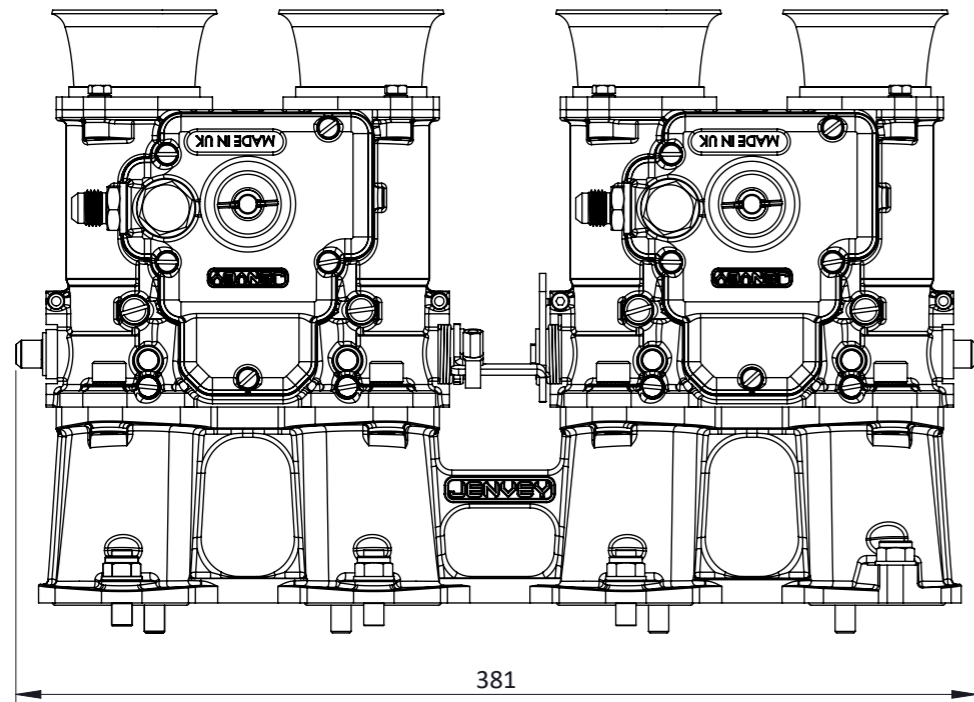

BMW INDIVIDUAL THROTTLE BODY (ITB) KIT FOR FUEL INJECTING YOUR BMW M10 4 CYLINDER, INCLUDES A PAIR OF TDP45 HERITAGE THROTTLE BODIES, INLET MANIFOLD AND 40mm LONG AIRHORNS.

THIS CLASSIC FUEL INJECTION KIT IS IDEAL FOR ROAD, TRACK OR RALLY USE. THE M10 ENGINE IS USED IN MANY BMW MODELS THROUGHOUT THE SEVENTIES INCLUDING THE ICONIC BMW 2002 AND NEW KLASSE.

IF YOU ARE LOOKING FOR THE ULTIMATE MOTORSPORT SETUP FOR YOUR CAR TRY OUR CKB03

KIT PERFORMANCE IS ENHANCED BY CAREFUL POSITIONING OF THE EFI FUEL INJECTORS BEING LOCATED FURTHER UPSTREAM THAN STANDARD AND DIRECTLY IN THE PART THROTTLE TURBULENCE OF THE BUTTERFLY. THIS ALLOWS INCREASED TIME/DISTANCE FOR IMPROVED FUEL MIXING INCREASING TORQUE AND POWER WHERE ITS NEEDED. OUR SPINDLES PROFILED TO MINIMISE CROSS SECTIONAL AREA AT FULL THROTTLE AND AN 8 DEGREE SHUT ANGLE (SHALLOWER THAN MOST) GIVES FINER CONTROL AT SMALL THROTTLE OPENINGS.

THIS JENVEY KIT REQUIRES AN AFTERMARKET ECU.

DRAWING AND OTHER INFORMATION CAN BE FOUND AT THE BOTTOM OF THE PAGE

OPTION AND ACCESSORIES
 THROTTLE OPERATION CAN BE RAN WITH A CABLE LINKAGE KIT . (CLS2-TBU2)
 AN IDLE AIR SYSTEM CAN HELP MAKE ROAD CARS MORE USEABLE BUT IS NOT REQUIRED WITH ELECTRONIC ACTUATION
 THIS KIT COMES WITH 350CC INJECTORS
 FOR THE 40mm AIRHORNS WE RECOMMEND OUR INDIVIDUAL MESH FILTERS

Frame: 1 of 1

Version: 1

Tel: 01746 768810

Web: WWW.JENVEY.CO.UK

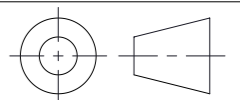

© JENVEY DYNAMICS LTD. 2025
 All rights reserved.