

CKFD19-TDA2-WEB - FORD 302 WINDSOR - Ø48mm TDA2 HERITAGE KIT

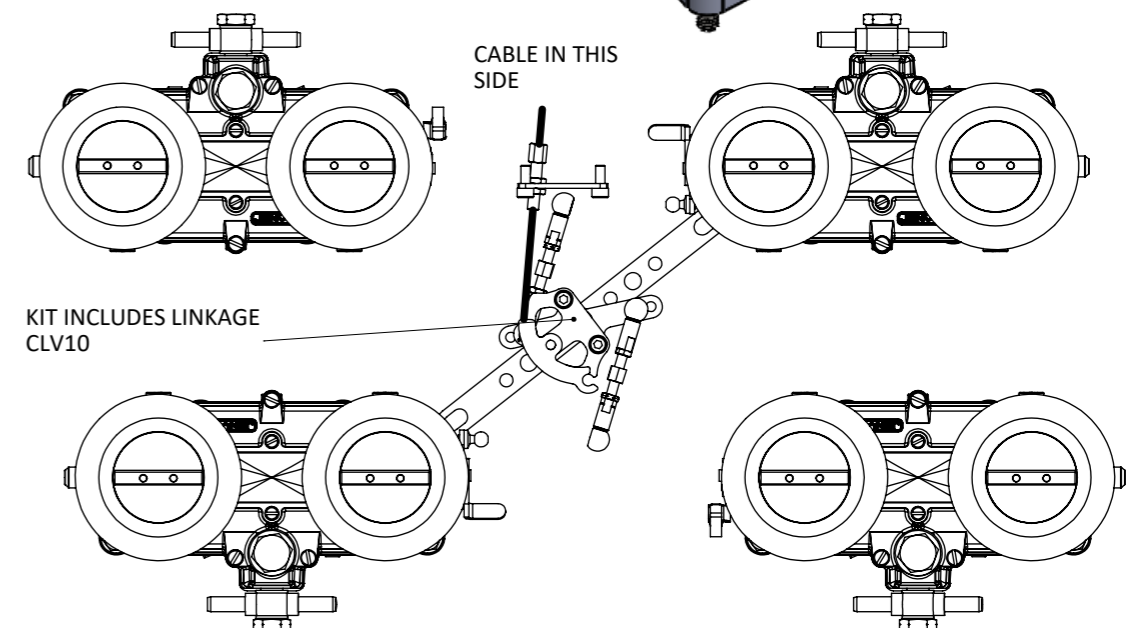

Engineered to win

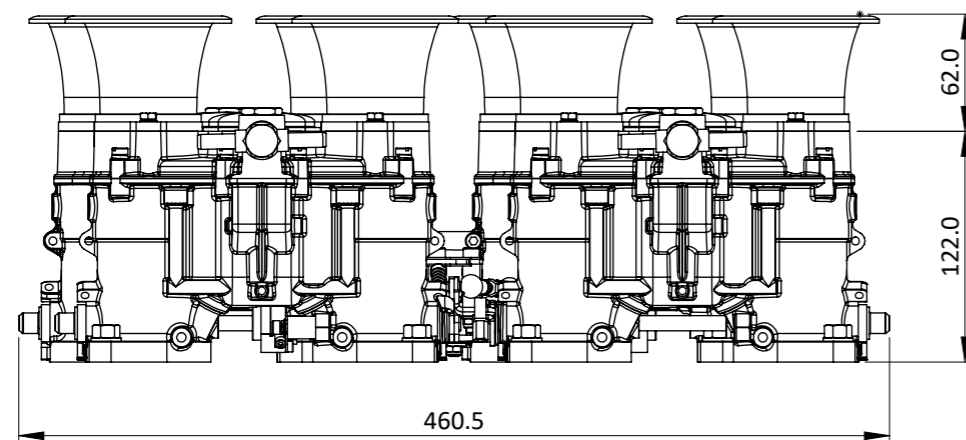
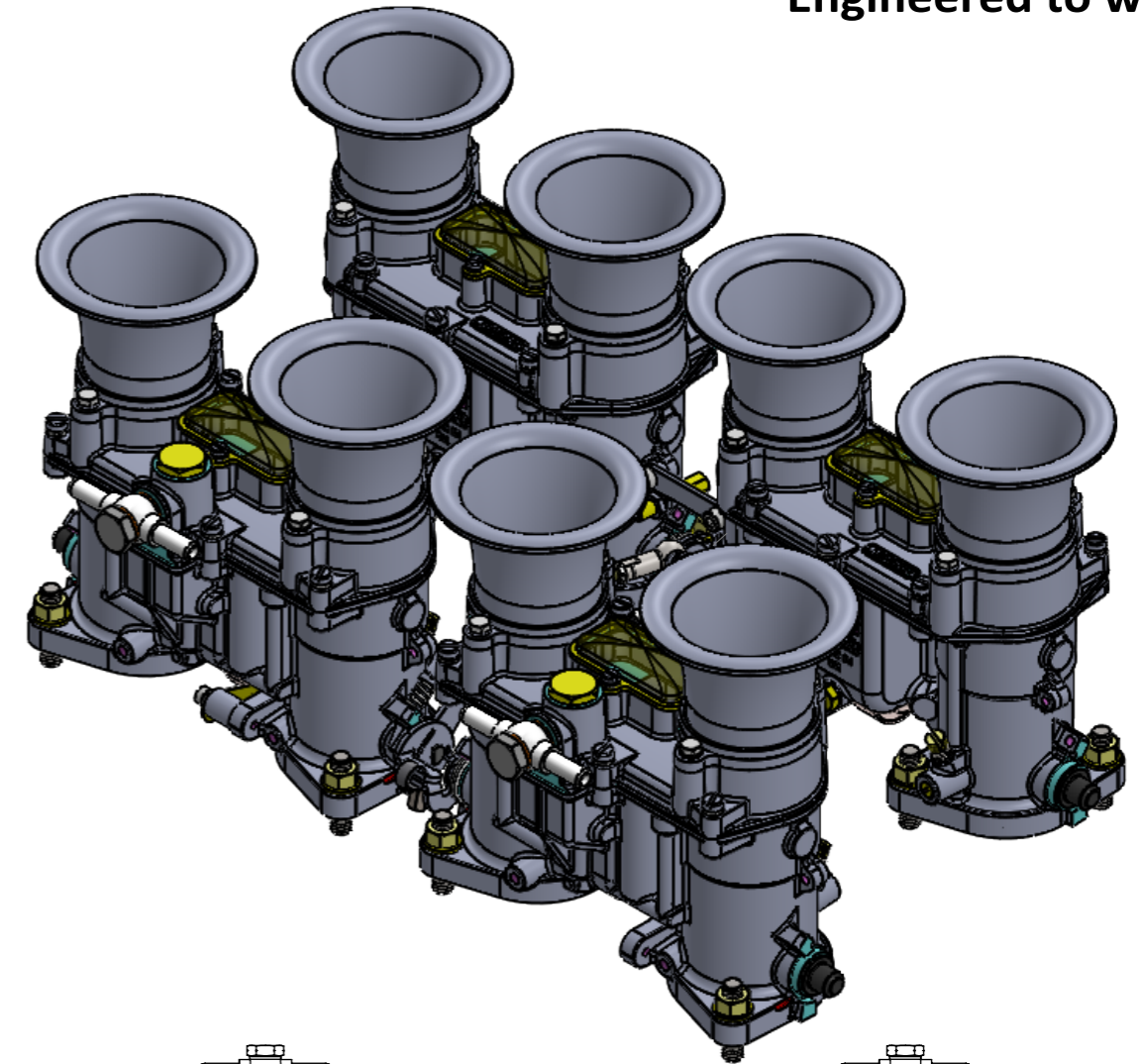
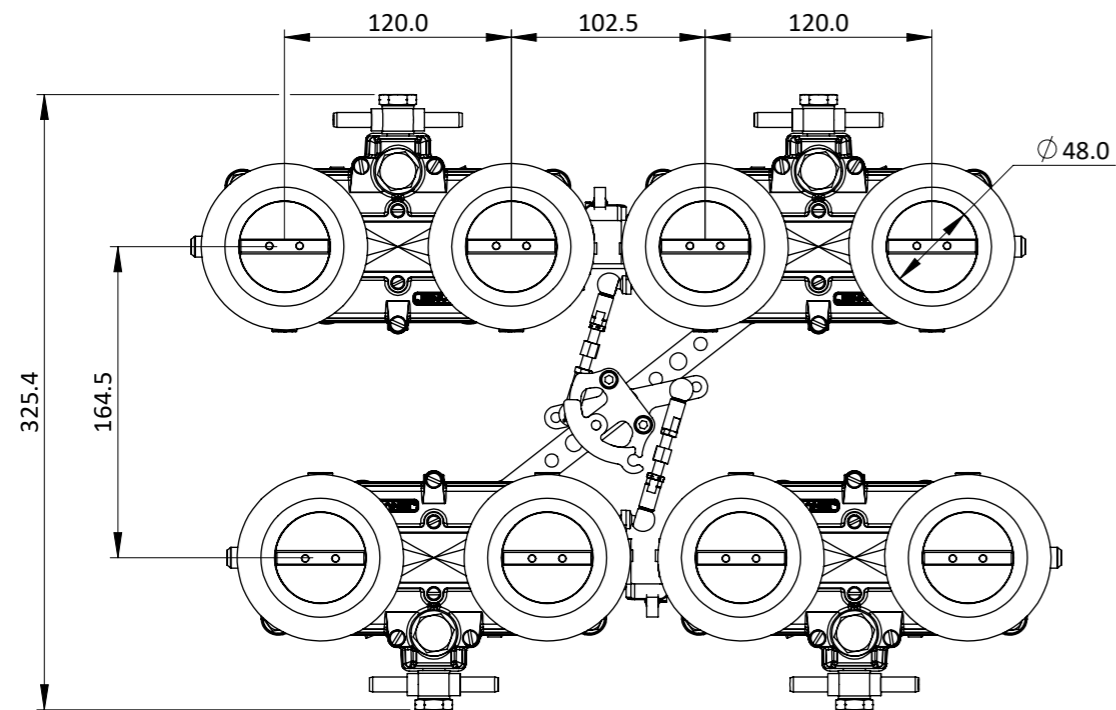

The Heritage body is designed with major dimensions identical to twin vertical carburetors from Weber, Dellorto, Solex etc. The fuel rail is integrated within the body lid, supplied with Bosch EV14 730cc/min injectors. The body comes with 'O' rings on the outlet, idle bypass adjustment, 60mm long air-horns and an internal throttle position sensor.
Operating data; Spindle rotation: 82 degrees.

Frame: 1 of 1

Version: 3

Tel 01746 768810

© JENVEY DYNAMICS LTD. 2021

Web WWW.JENVEY.CO.UK

