

CKJR04 - JAG V12 KIT

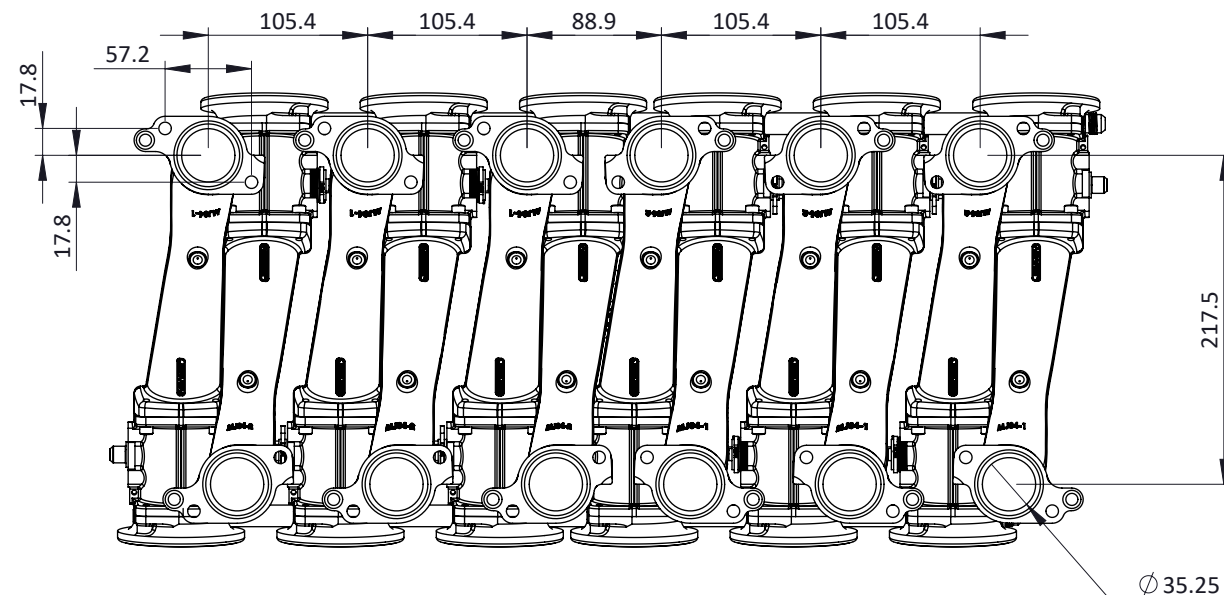

Engineered to win

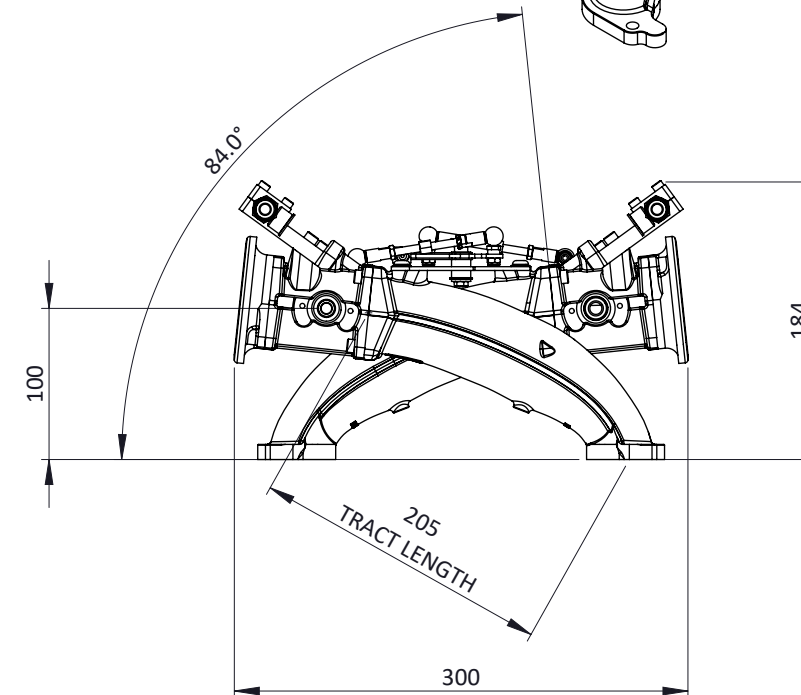
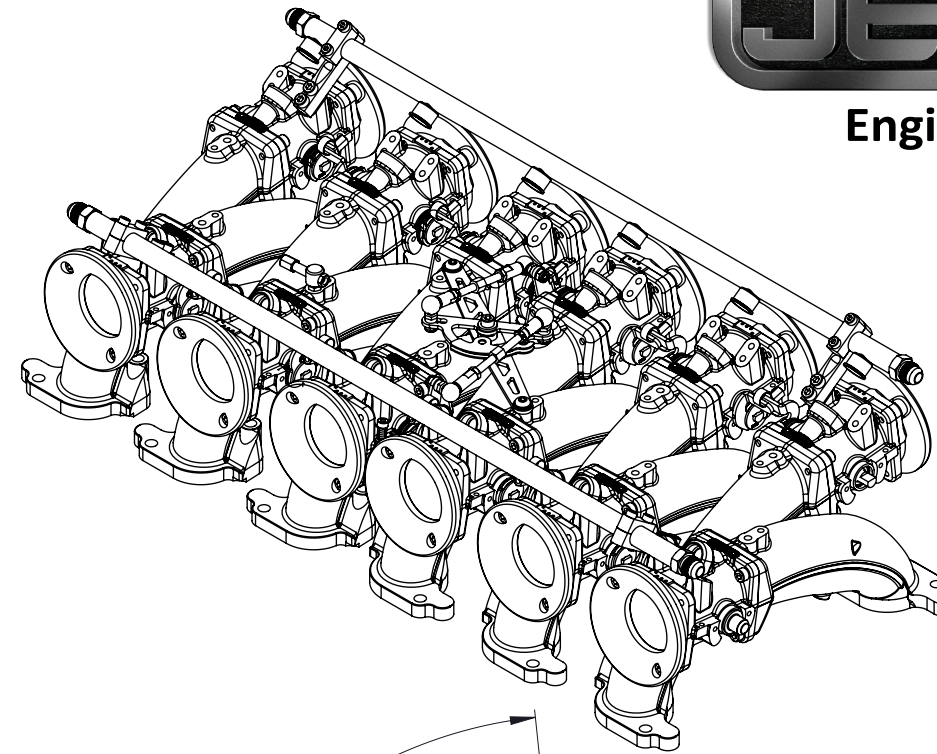
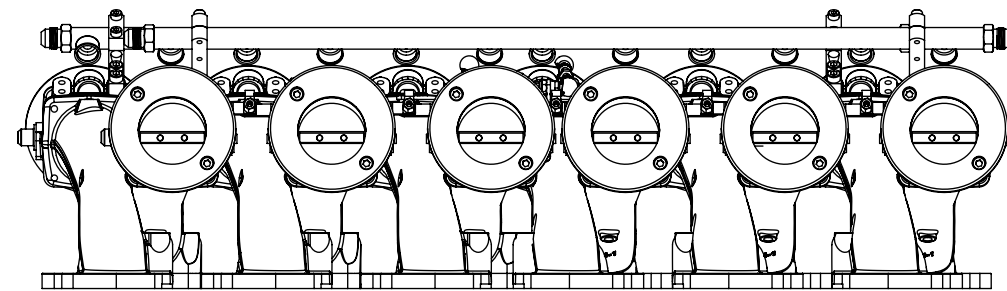
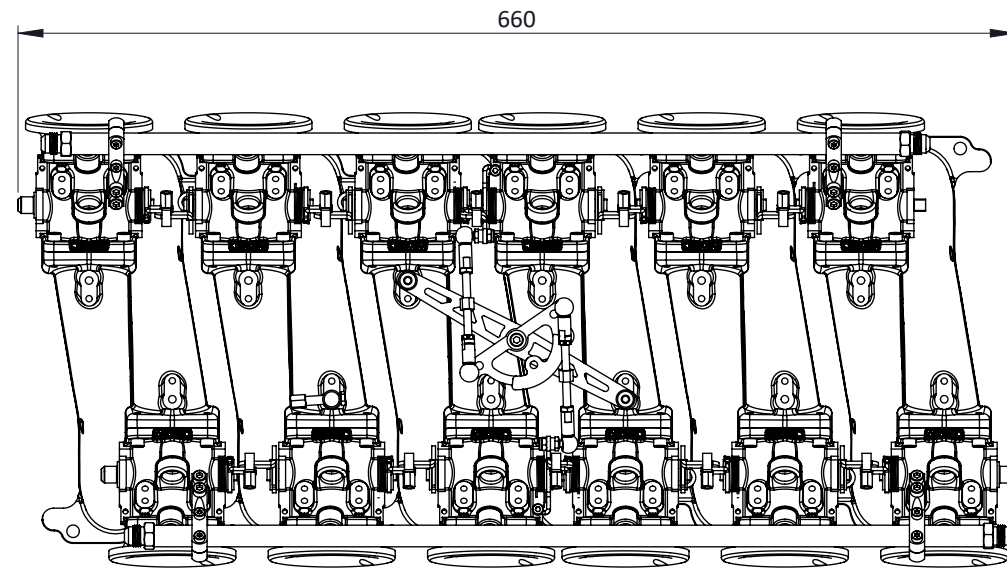

FLANGES FOR JENVEY SINGLE (SF, SFS) THROTTLE BODIES.
 MAY BE PORTED UP TO 48MM WITH SUFFICIENT MATERIAL TO ALLOW FOR MATCHING TO PORTED CYLINDER HEADS.
 UNDRILLED BOSSES ON THE UNDERSIDE OF THE MANIFOLD FOR IDLE AIR/ VACUUM TAKE-OFF ETC.

OUTLET FLANGE INCLUDES O-RING SEALS FOR THE INTAKE PORT AND TO BLOCK THE AIR INJECTION HOLES ON THE CYLINDER HEAD.

Frame: 1 of 1

Version: 2

Tel 01746 768810

© JENVEY DYNAMICS LTD. 2015

Web WWW.JENVEY.CO.UK

