

CKMZ01-RH-WEB - Mazda MX5 1.8 NB Right Hand Drive - TH45 Kit

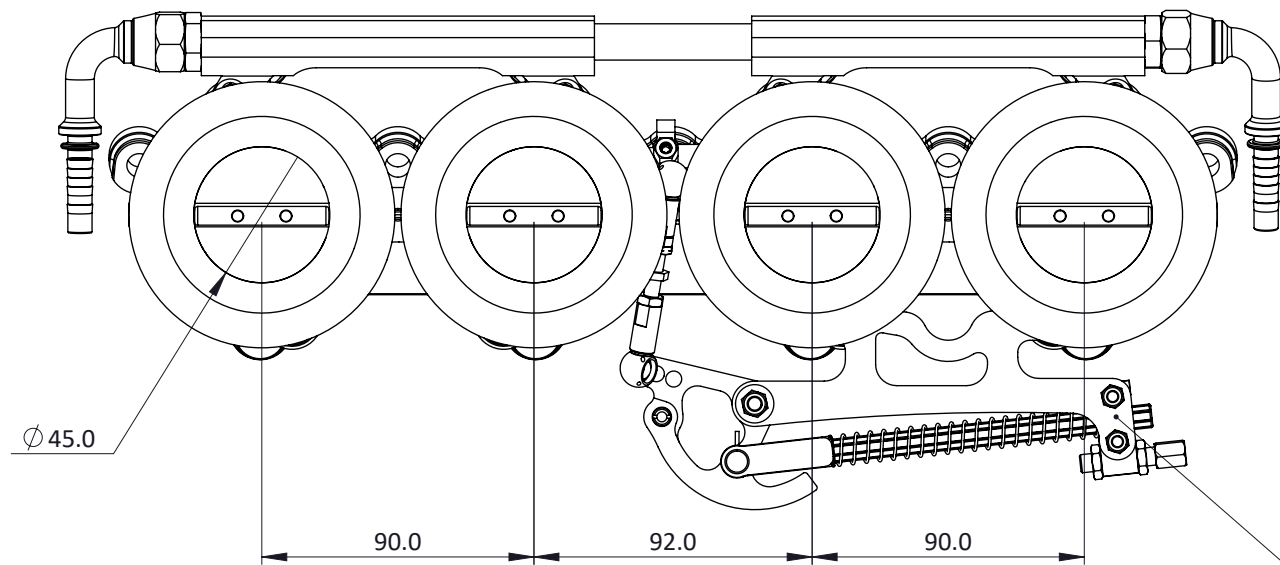

Engineered to win

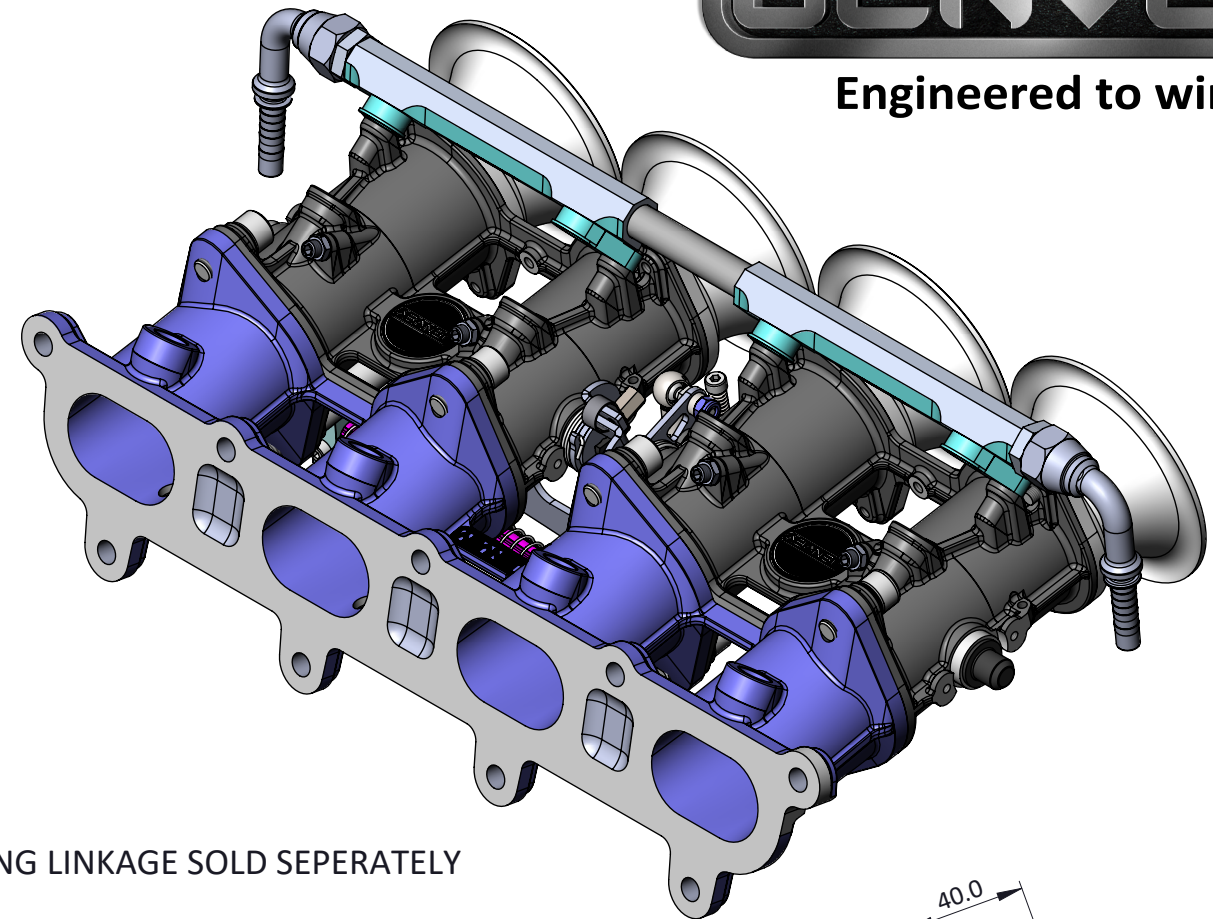

UNDERSLUNG LINKAGE SOLD SEPERATELY

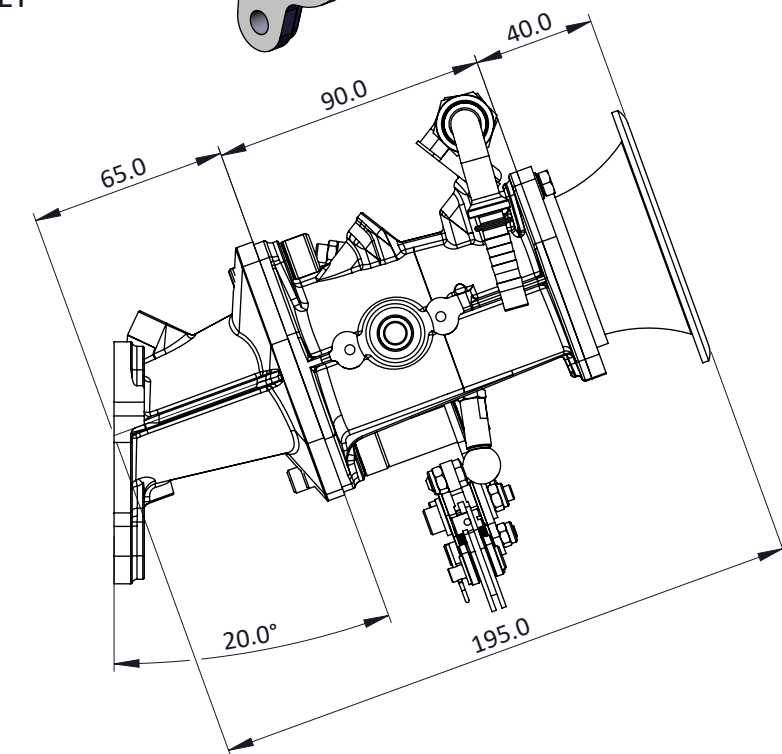
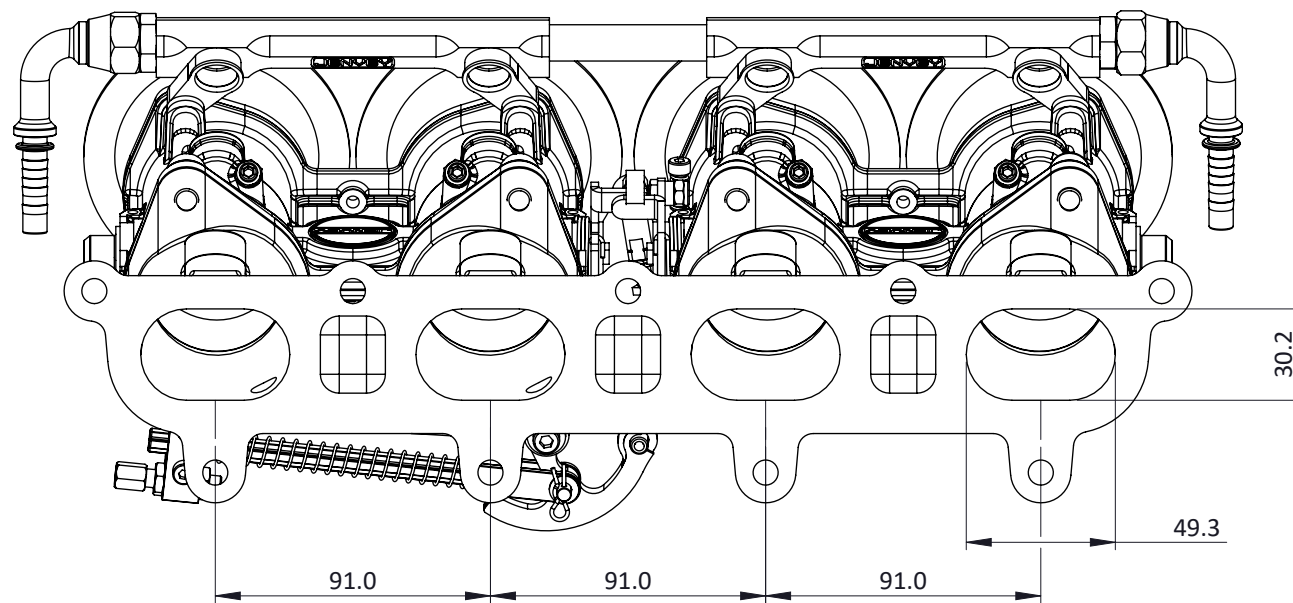

A KIT FOR RIGHT HAND DRIVE NB 1.8L MX5'S, WHICH INCLUDES A DCOE INLET MANIFOLD, 90MM LONG TH THROTTLE BODIES, FUEL RAIL AND AIRHORNS.

THE KIT ALSO INLCUDES 90° SWIVEL FUEL FITTINGS FOR 8MM PUSH-ON HOSE, FOR BETTER FUEL LINE ROUTING AND CAN BE FITTED WITH A FORWARDS FACING UNDERSLUNG STYLE LINKAGE (CLS2-TBU2) FOR BETTER THROTTLE CABLE ROUTING.

FOR A BACKPLATE AND FILTER TO FIT INSIDE A RHD CAR WITHOUT MODIFICATION THE BELOW MUST BE USED:

- ABB2/0-92OFF - 12MM OFFSET BACKPLATE TO SUIT RHD 1.8 MX5'S
- ABF2/65 - AIR FILTER 430 X 140 X 65 DOME (MUST BE DOMED TO CLEAR CLUTCH RESEVOIR)
- SHORT STYLE INJECTORS (E.G BOSCH EV14 COMPACT/ IWP PICO INJECTOR)

TB STYLE, 118MM LONG THROTTLE BODIES CAN BE USED WITH RIGHT HAND DRIVE MX5, BUT WILL NEED THE CLUTCH RESEVOIR AND MASTER CYLINDER RELOCATED TO FIT A BACKPLATE AND FILTER.

Frame: 1 of 1

Version: 1

Tel 01746 768810

© JENVEY DYNAMICS LTD. 2021

Web WWW.JENVEY.CO.UK

