

# CKMZ03 - MAZDA MX5 1.6L - TB42 KIT

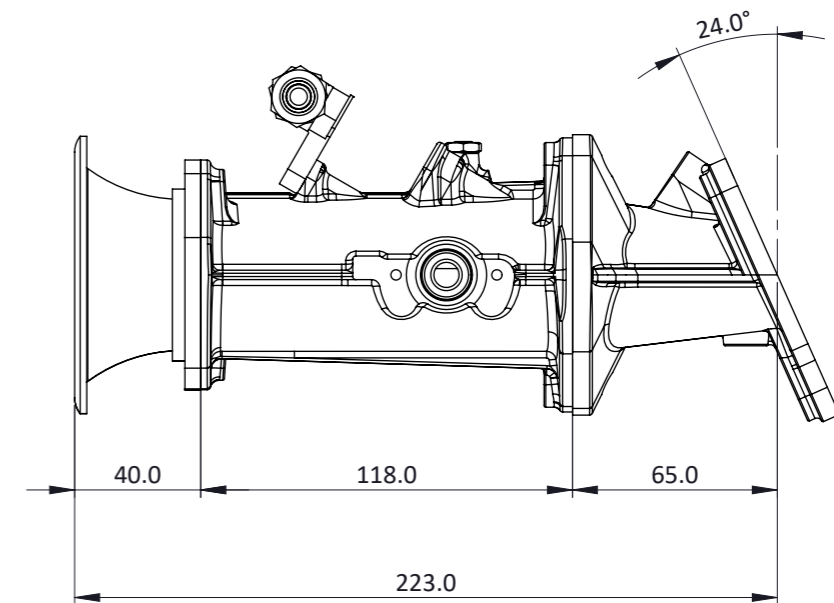

Engineered to win

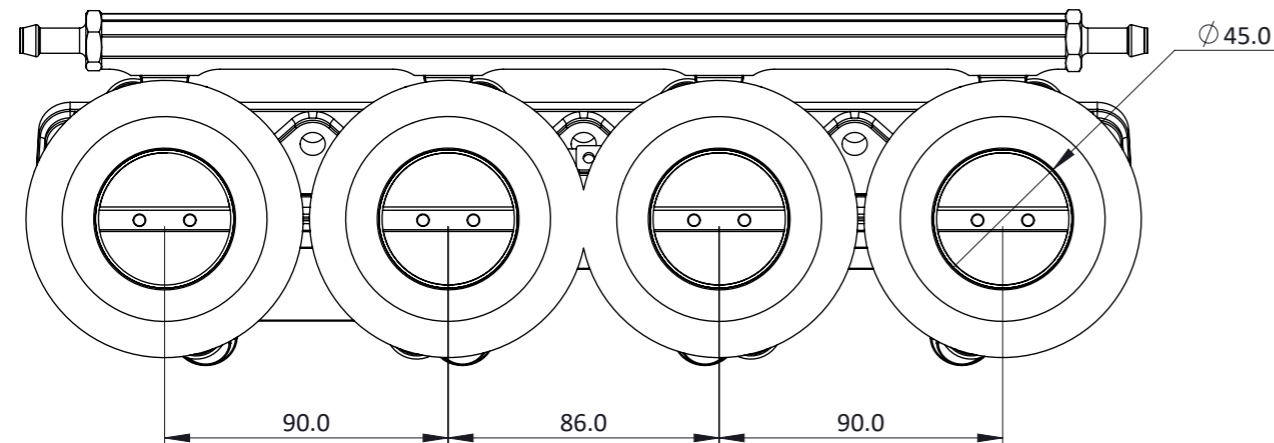
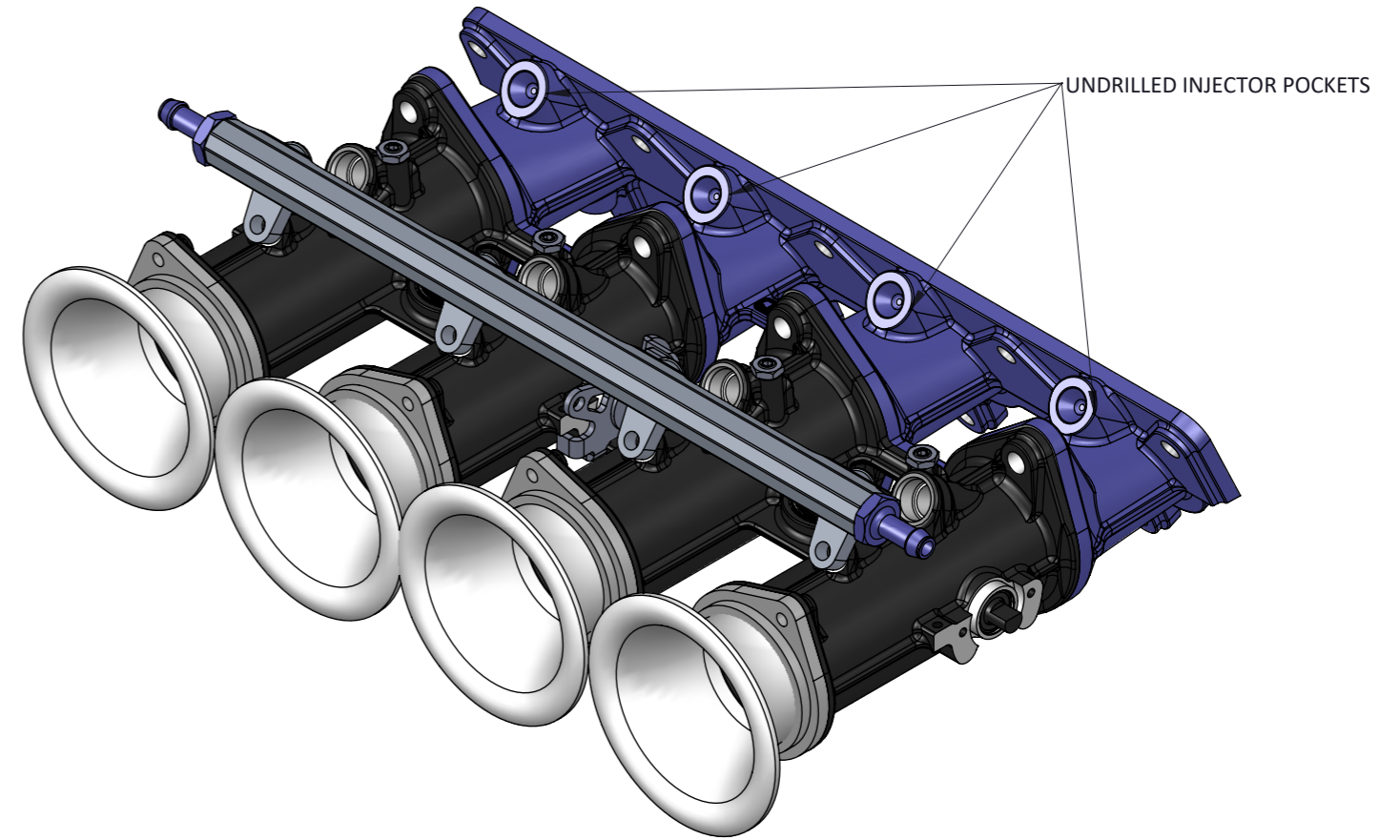
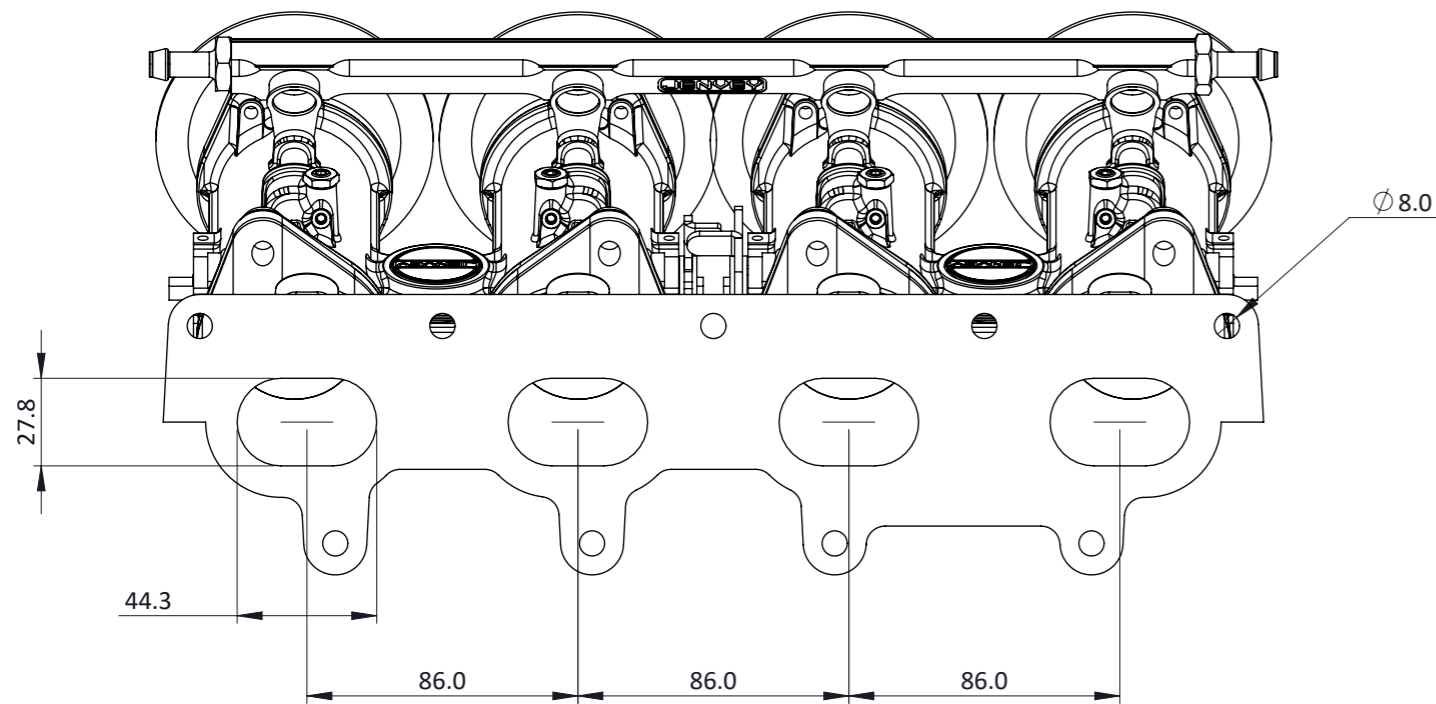

A TWIN THROTTLE BODY KIT FOR THE MK1 & MK2 MAZDA 1.6L EFI ENGINE IN THE MX5/MIATA & EUNOS.

THE KIT CONTAINS AN INLET MANIFOLD, TWO TB42 TWIN DCOE THROTTLE BODIES, FOUR INJECTOR POCKET PLUGS FOR THE CYLINDER HEAD, TBR ALUMINIUM FUEL RAIL WITH 8mm PUSH ON FITTINGS, AND FOUR Ø45x40mm AIRHORNS.

MANIFOLD INCLUDES OPTIONAL UNDRILLED INJECTOR POCKETS, WHICH CAN BE MACHINED ON REQUEST.

Frame: 1 of 1

Version:

Tel 01746 768810

© JENVEY DYNAMICS LTD. 2015

Web WWW.JENVEY.CO.UK

