

CKPE07 - LINKAGE KIT FLAT - PORSCHE HERITAGE

FOR PORSCHE 3 STUD AIR COOLED 964 STYLE CARS 1989-1994

USED ON THE 3.6L & 3.8L ENGINE

COMES WITH B30 PHENOLIC 9MM INSULATED SPACERS, FIXING KIT & LINKAGE



Engineered to win

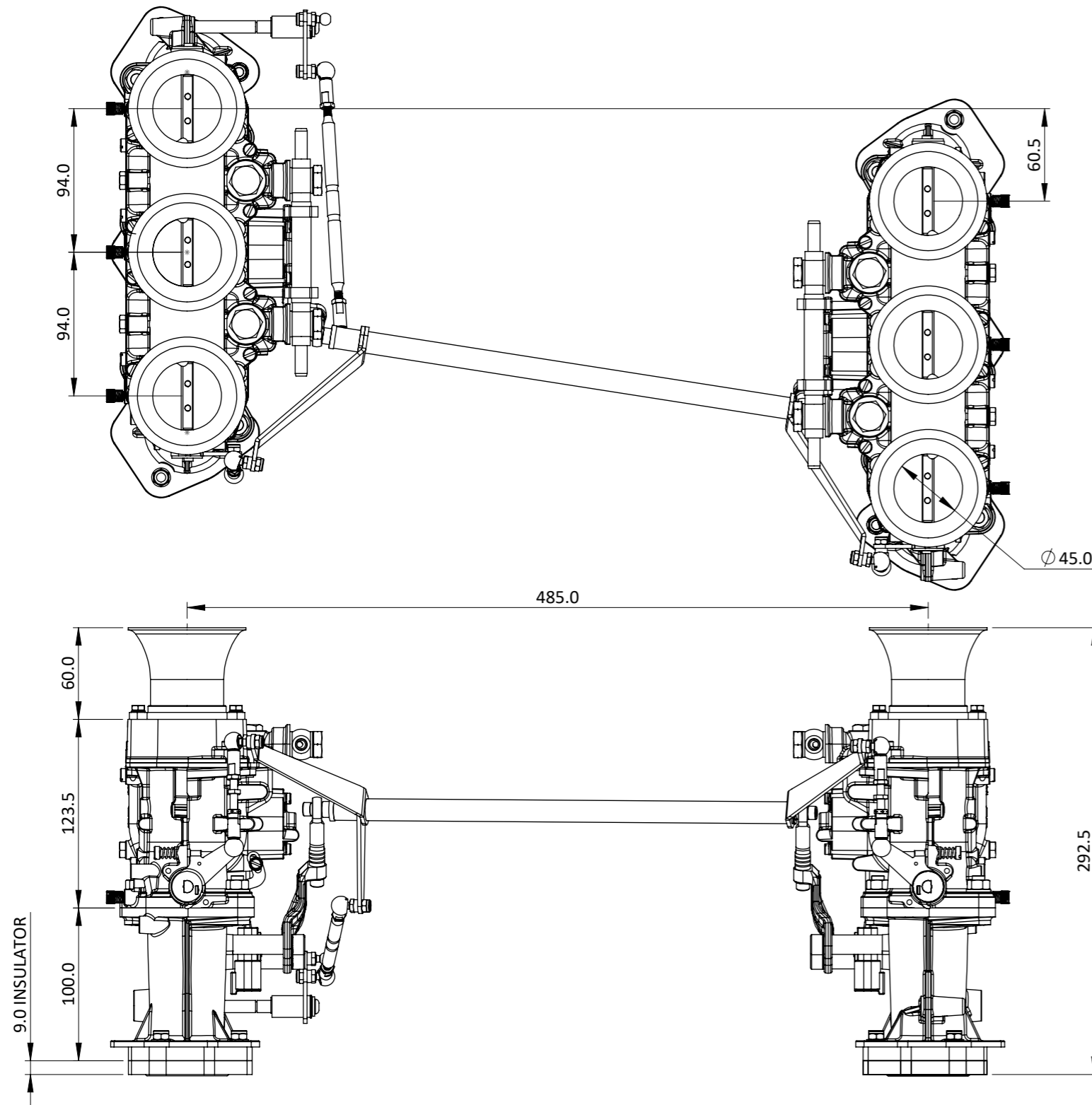
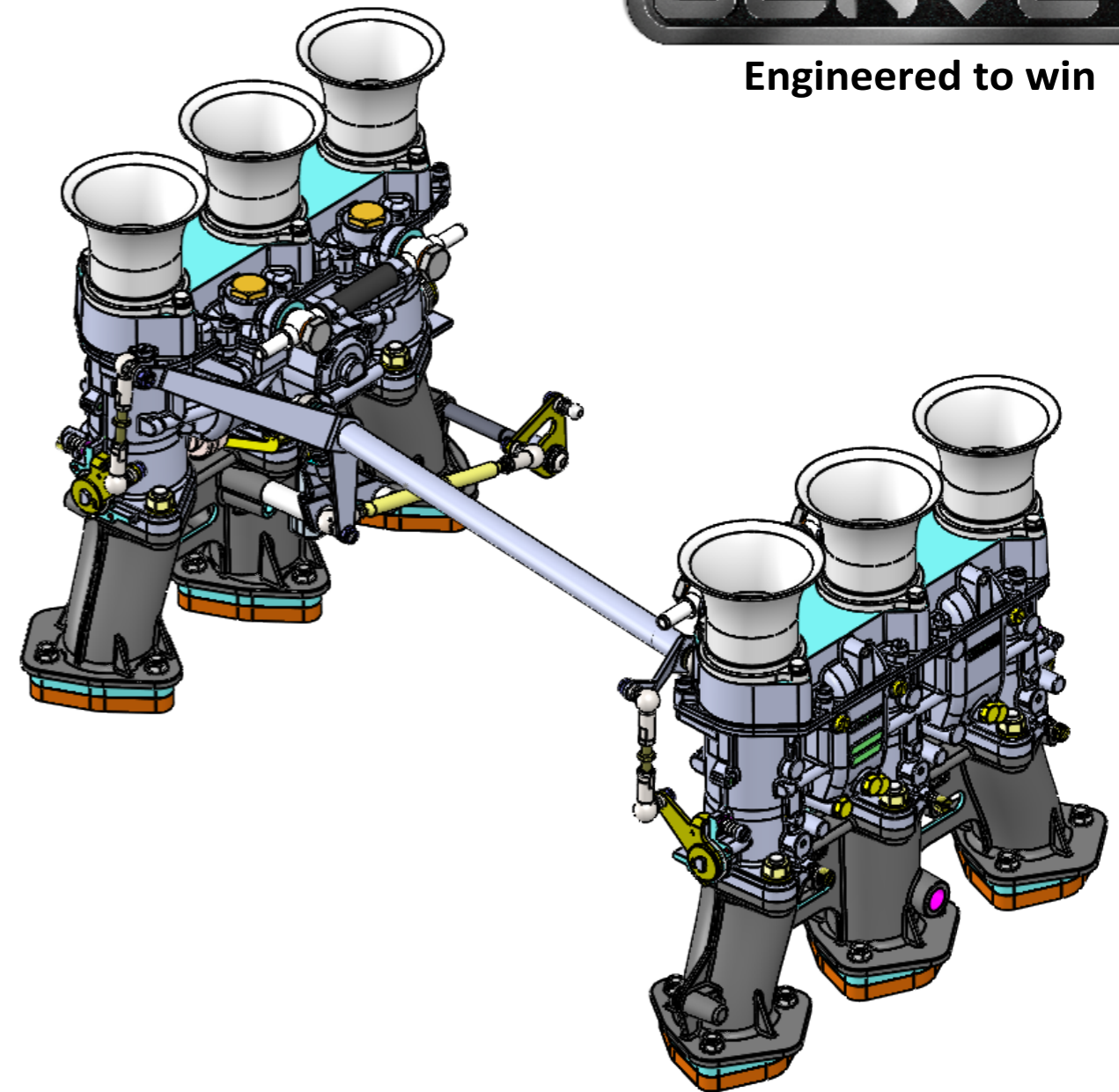

The Heritage triple body is designed with major dimensions identical to triple vertical carburetors.

Bodies are available Ø45 with manifold outlet Ø41

The fuel rail is integrated within the body lid, supplied with Bosch EV14 350cc/min (237g) injectors. Resistance 12 Ohm

The body comes with idle bypass adjustment, interconnecting link, internal throttle positioning sensor & injector loom with a 4 pin Deutsch DTM male connector.

Spindle rotation: 82 degrees. TP goes from 3.35 V at idle to 0.65 V open. Loom Pin out on drawing TDA3.

All bodies have been balanced and tested before leaving the factory.

Frame: 1 of 1

Version: 1

Tel 01746 768810

© JENVEY DYNAMICS LTD. 2015

Web WWW.JENVEY.CO.UK

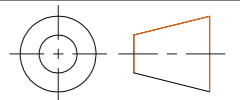

CLF4 - WEB - LINKAGE KIT FLAT - PORSCHE HERITAGE



Engineered to win

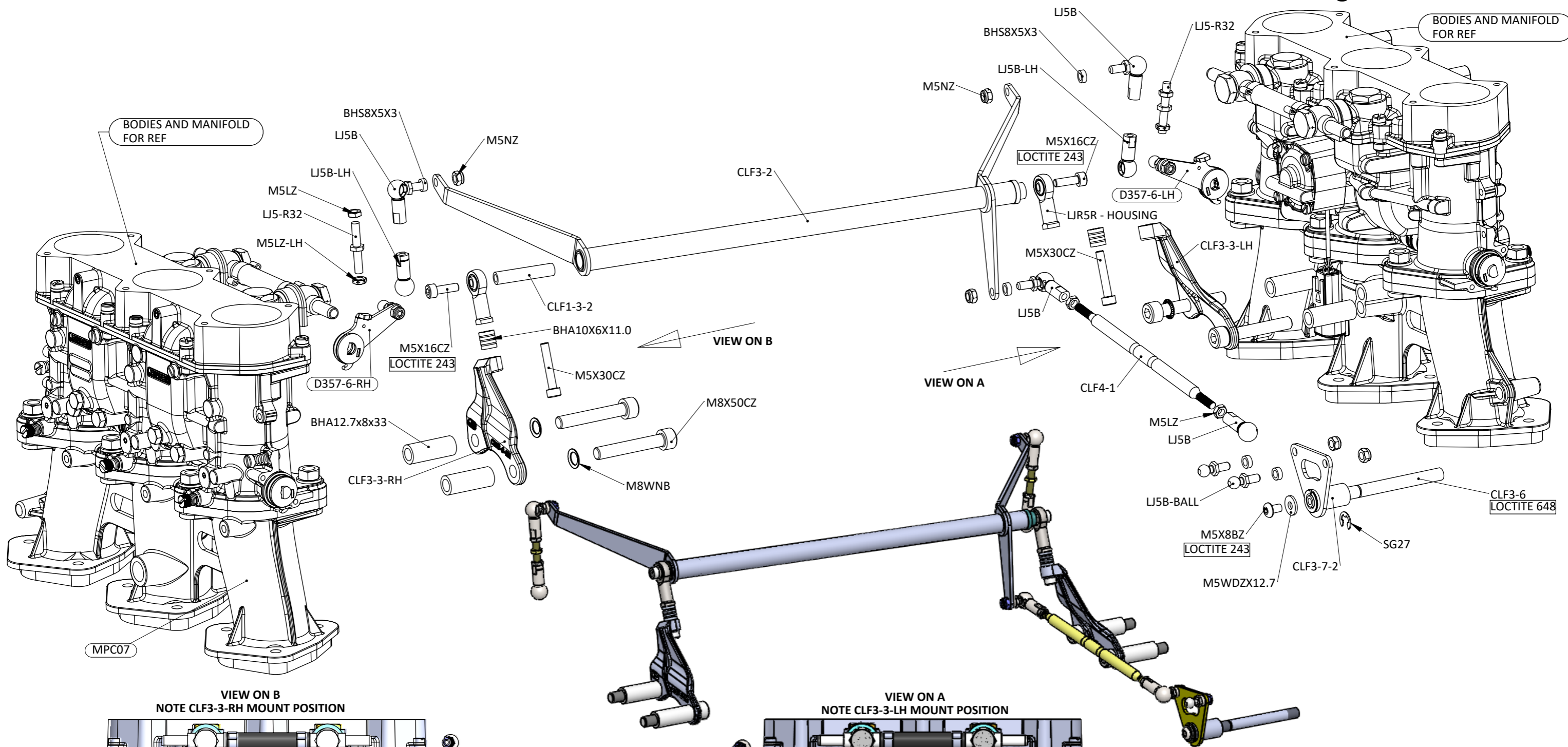

VIEW ON B
NOTE CLF3-3-RH MOUNT POSITION

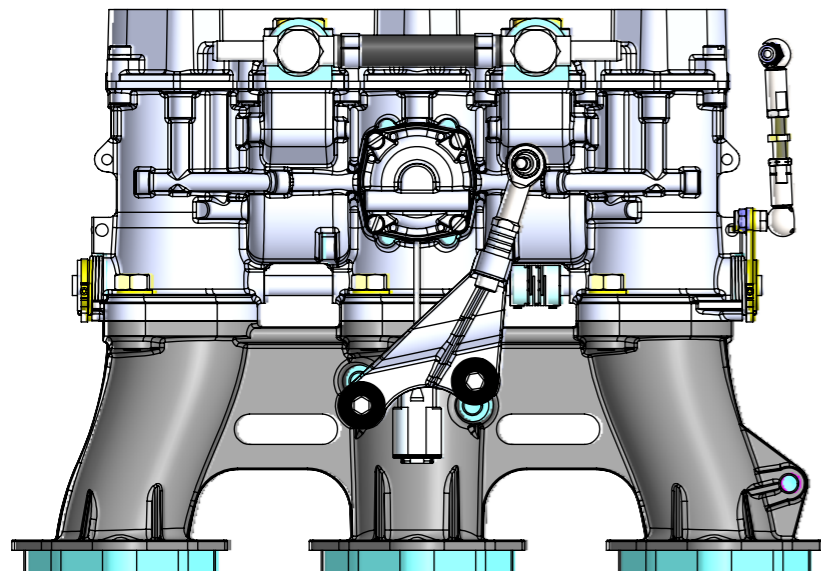

VIEW ON A
NOTE CLF3-3-LH MOUNT POSITION

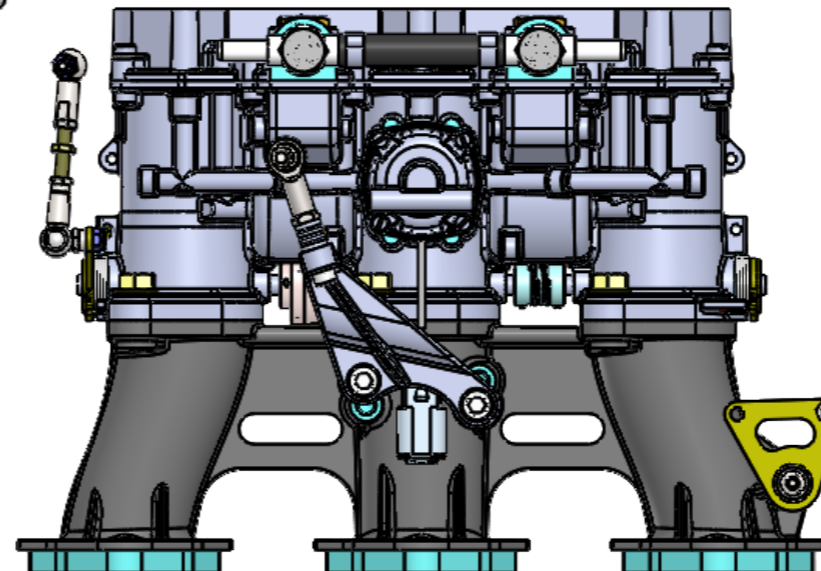

Frame: 1 of 1

Version: 1

Tel 01746 768810

Web WWW.JENVEY.CO.UK

© JENVEY DYNAMICS LTD. 2021

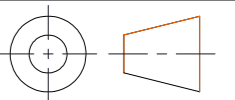

TDA3-XX - PORSCHE TRIPLE IDA



Engineered to win

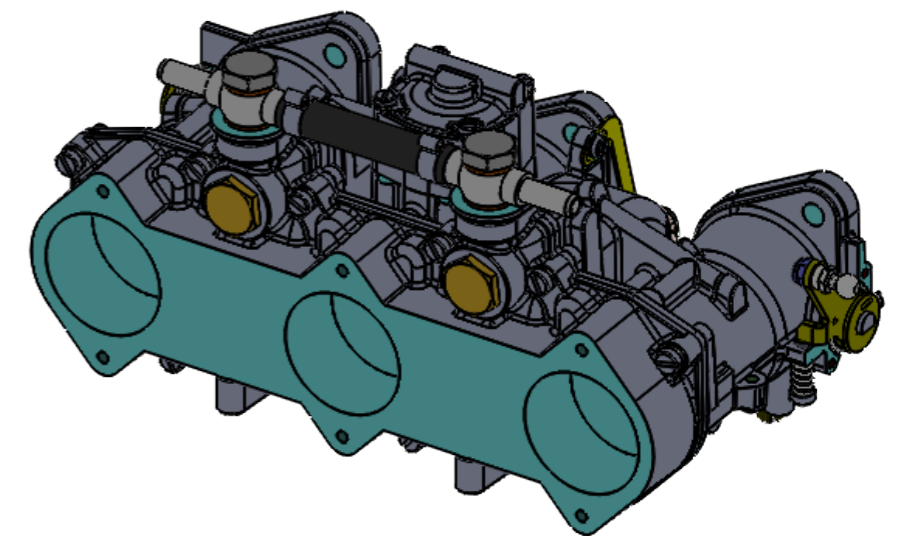
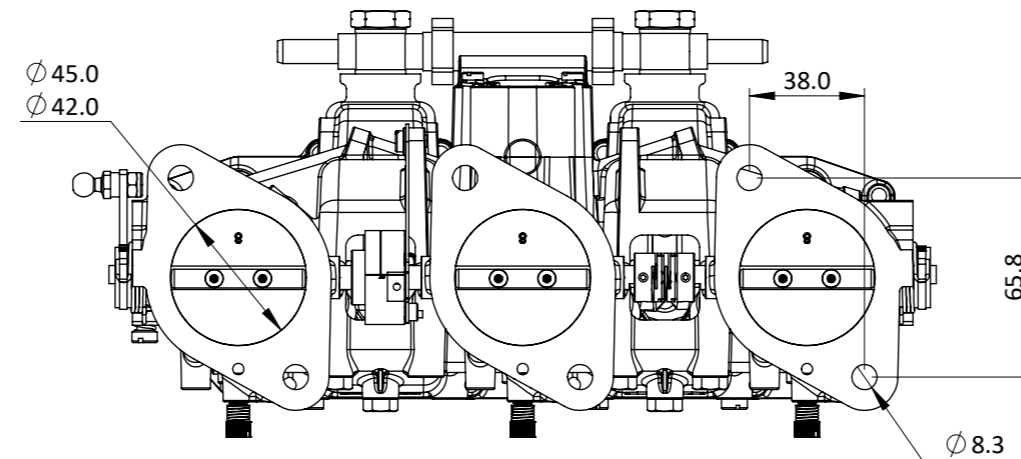
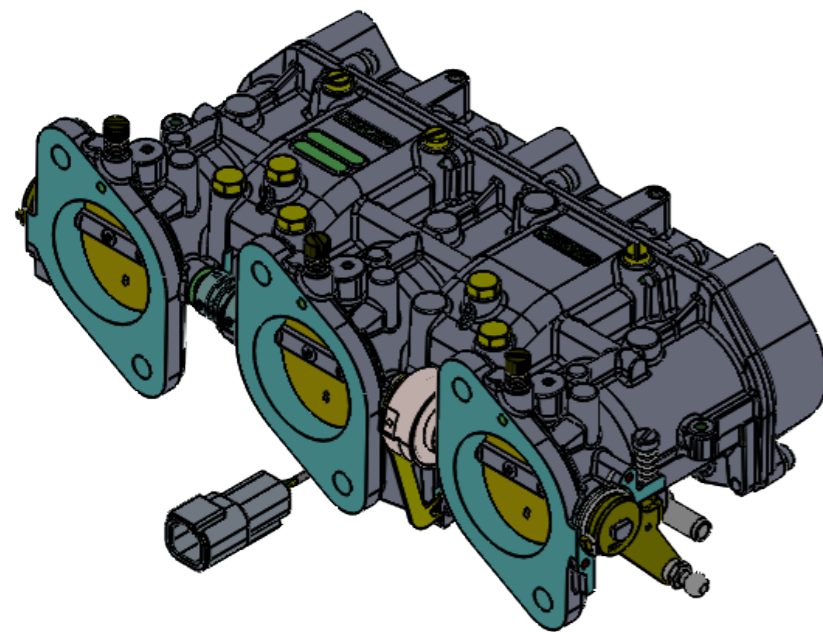
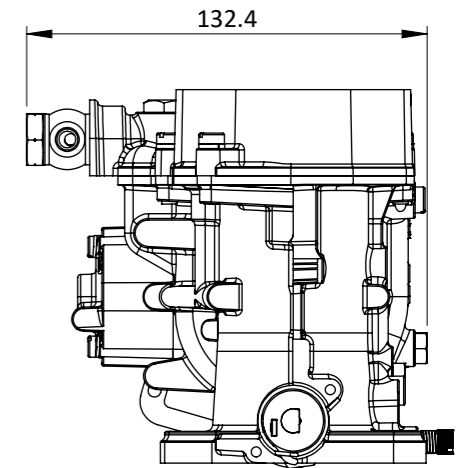
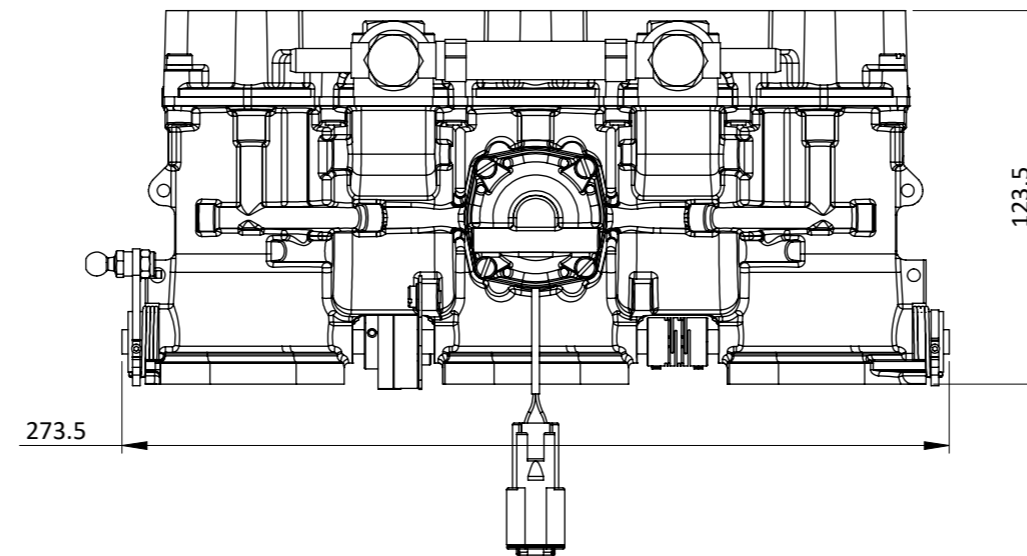
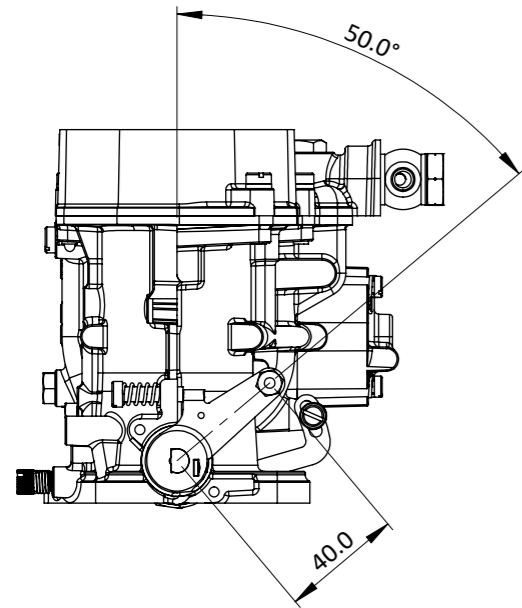
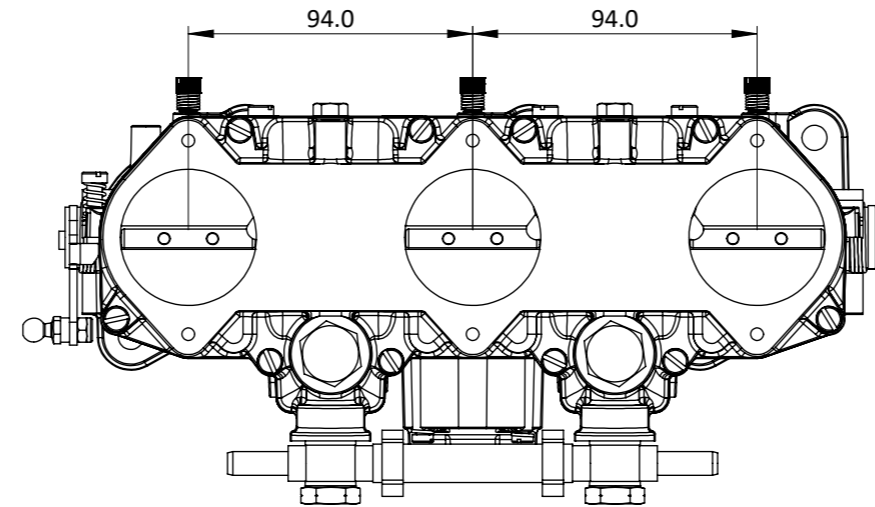

The Heritage triple body is designed with major dimensions identical to triple vertical carburetors from Weber.

The fuel rail is integrated within the body lid.

The body comes with idle bypass adjustment, interconnecting link, internal throttle positioning sensor & injector loom with a 4 pin Deutsch DTM male connector.

Operating data; Spindle rotation: 82 degrees.

Frame: 1 of 2

Version: 6

Tel 01746 768810

© JENVEY DYNAMICS LTD. 2021

Web WWW.JENVEY.CO.UK

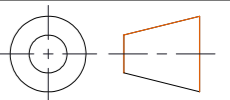

TDA3-XX - PORSCHE TRIPLE IDA



Engineered to win

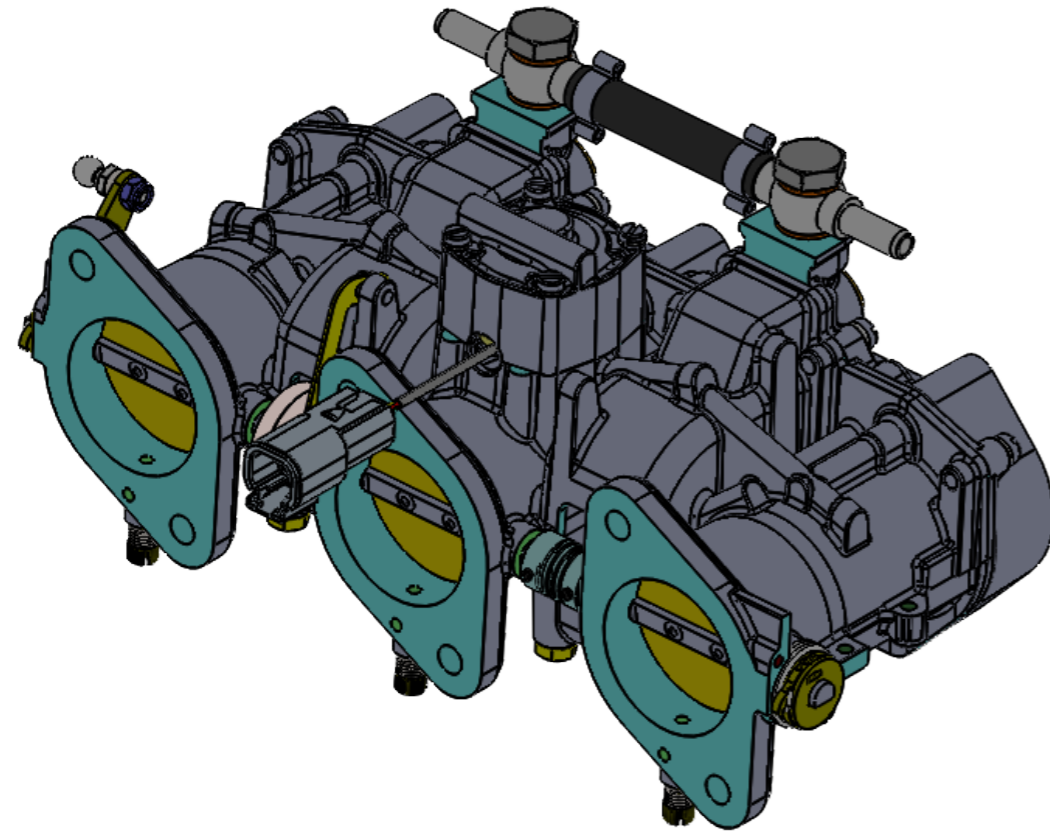

- Brass hex nut and brass slotted screw are for visual appearance only and should not be removed.
- Throttle position sensor has been set to 3.35 volts. This can be adjusted from 3.28 volts to 3.56 volts. Loosening the M4 slotted screw on the TP adjuster strap, rotating then re tighten.
- Spindle rotation: 82 degrees. TP goes from 3.35 V at idle to 0.65 V open.
- The body features idle bypass adjustment.
- All bodies have been balanced and tested before leaving the factory.
- Fitted with Bosch EV14 350cc/237g injectors - Resistance 12 Ohm

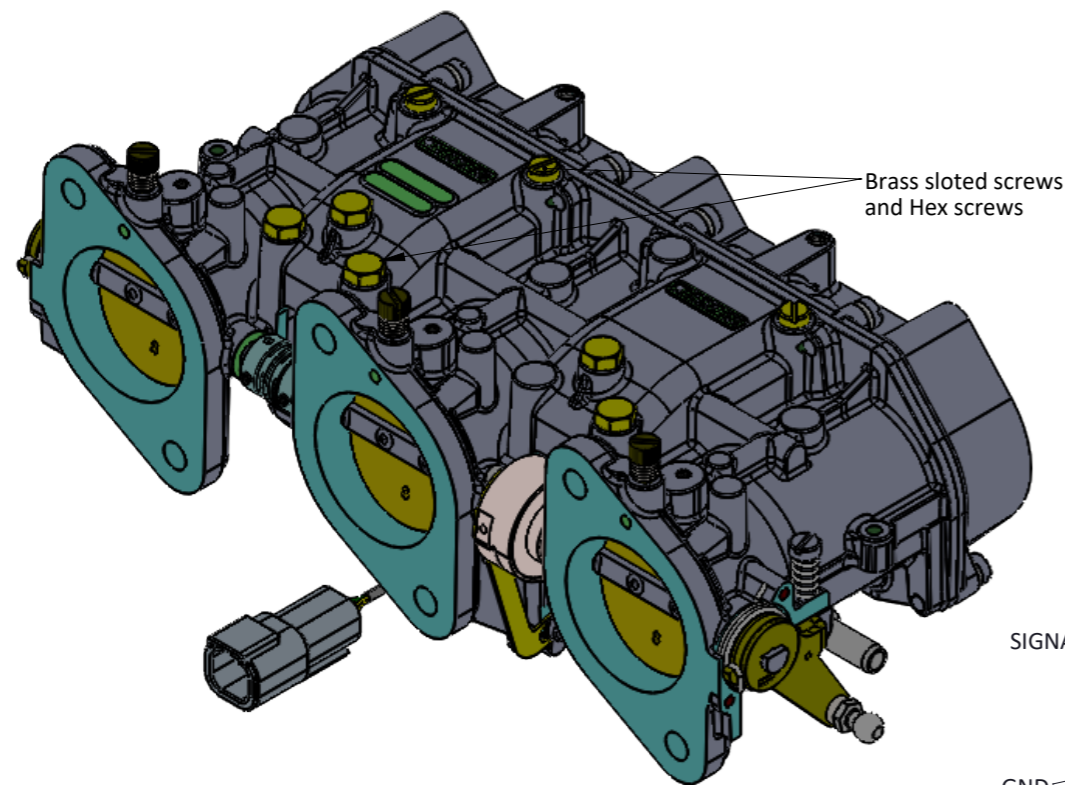

Brass slotted screws and Hex screws

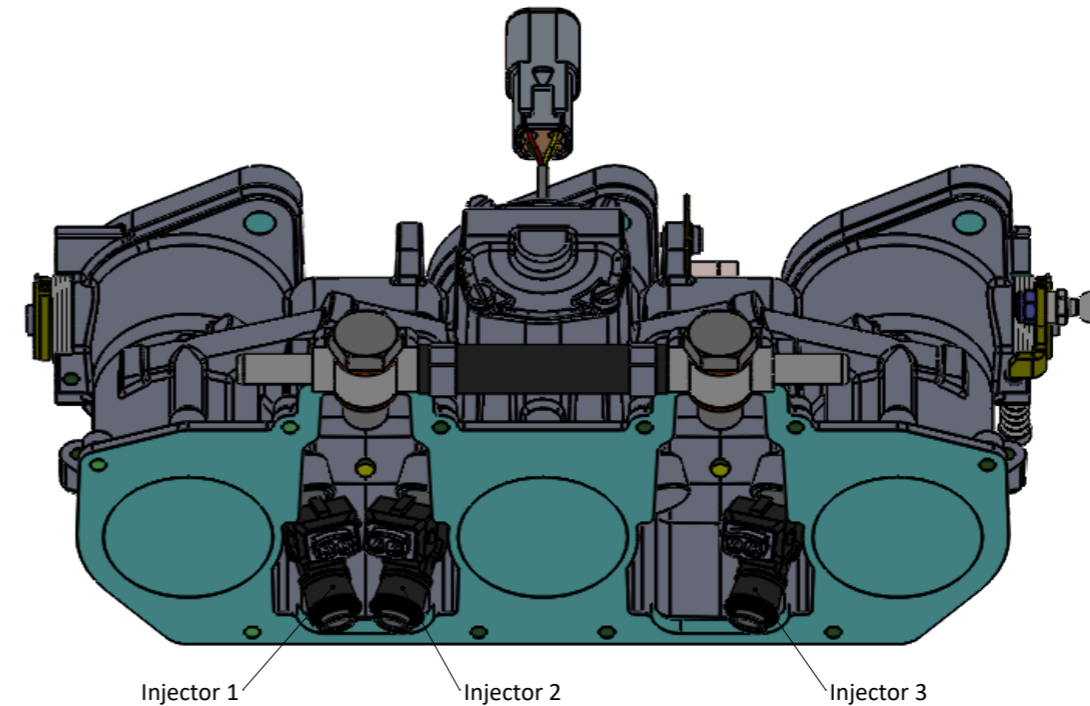

Injector 1

Injector 2

Injector 3

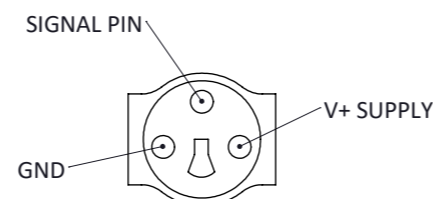

Throttle Position Sensor Pin Out

Injector loom Plug DTM Deutsch male

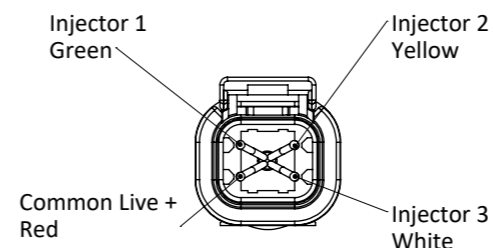

Frame: 2 of 2

Version: 6

Tel 01746 768810

© JENVEY DYNAMICS LTD. 2015

Web WWW.JENVEY.CO.UK