

CLJ-3.8RH - JAGUAR XK6 RH 3.8 LINKAGE

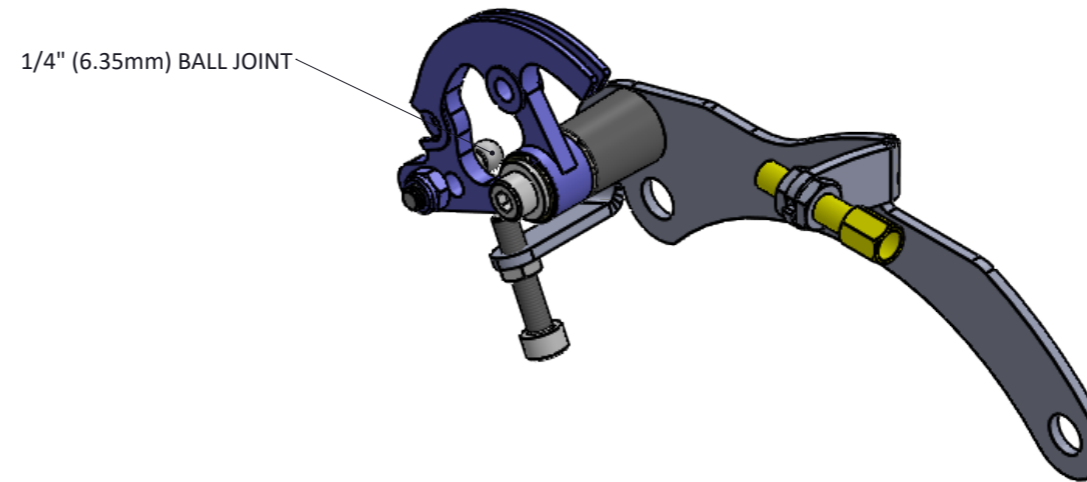

Engineered to win



D352-L3.8

THROTTLE CABLE ADJUSTER

FULL THROTTLE STOP

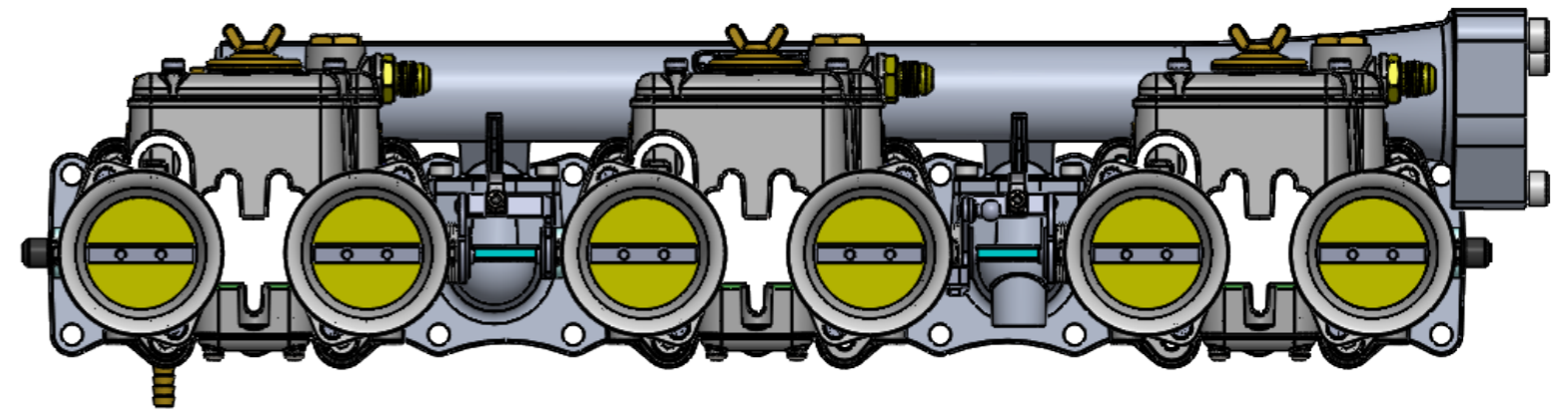

CLS2-TBU2

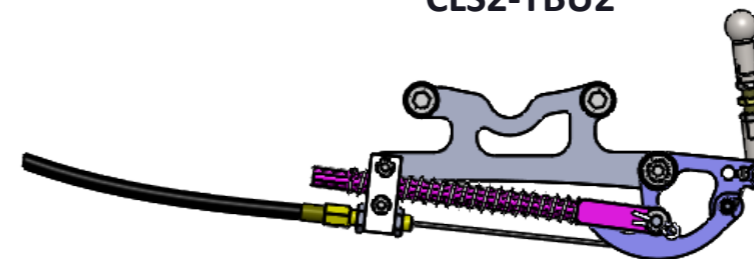

CLJ-3.8RH - ACCELERATOR LINKAGE KIT TO SUIT THE RH DRIVE JAGUAR E-TYPE SERIES 1-2, WITH 3.8L ENGINES, INCLUDES THE FOLLOWING PARTS:

D352-L3.8 - DIRECT REPLACEMENT FOR THE OEM MECHANICAL LINKAGE BRACKET WHICH MOUNTS TO THE BRACKET ABOVE THE BRAKE BOOST ON THE E-TYPE, & LINKS TO THE STANDARD LINKAGE ROD FROM THE PEDAL

CLS2-TBU2 - LINKAGE WHICH MOUNTS TO THE UNDERSIDE OF DCOE THROTTLE BODIES, INCLUDES THE THROTTLE CABLE WHICH LINKS THE TWO ASSEMBLIES, CONVERTING THE OEM MECHANICAL LINKAGE INTO CABLE.

Frame: 1 of 1

Version: 2

Tel 01746 768810

© JENVEY DYNAMICS LTD. 2015

Web WWW.JENVEY.CO.UK

