

# ETA2 - ELECTRONIC ACTUATOR WITH OPERATING WHEEL



Engineered to win

The Jenvey ETA2 Motorsport electronic throttle actuator has been created specifically for use with motorsport and high-performance engines. It will operate Jenvey individual throttle body systems as well as other applications requiring fast and accurate response within its operating range.

JENVEY recommend that set-up and tuning is only undertaken in conjunction with ECU suppliers and/or their recommended agents.

This product cannot be used with standard vehicle ECUs.

Mountings for linkage, position sensor and return springs on both sides.

Total rotation to hard stops: 100°

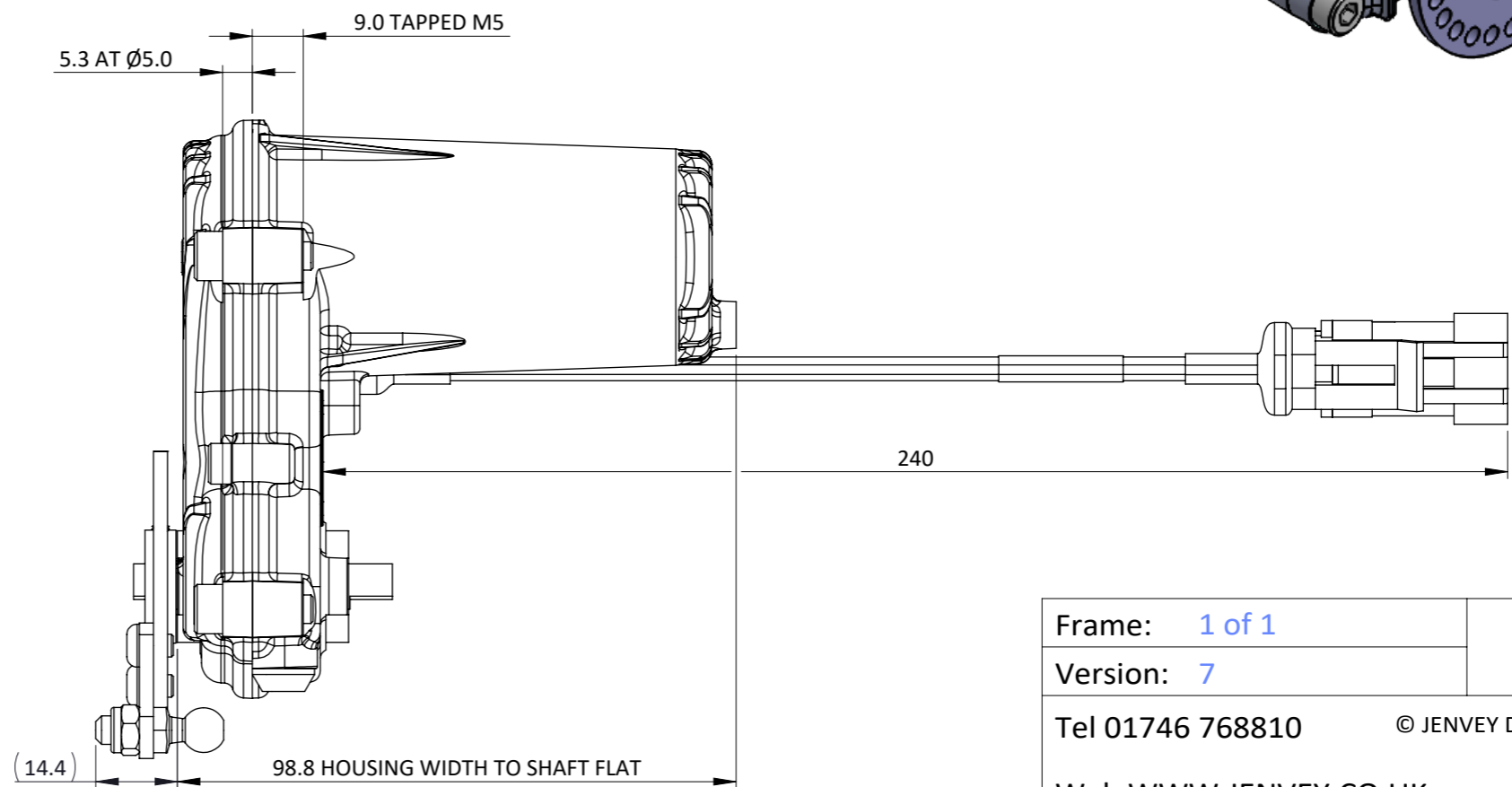
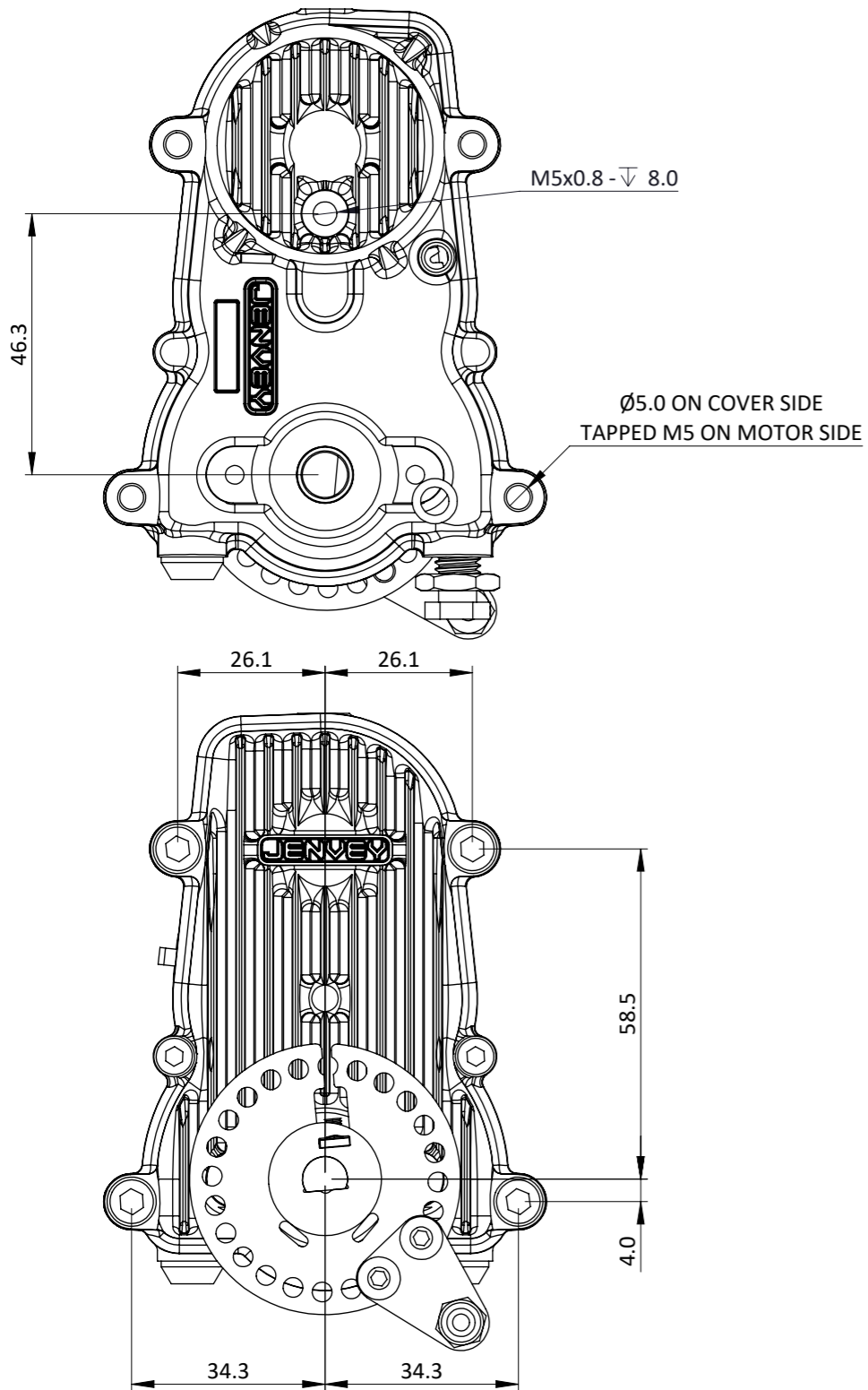
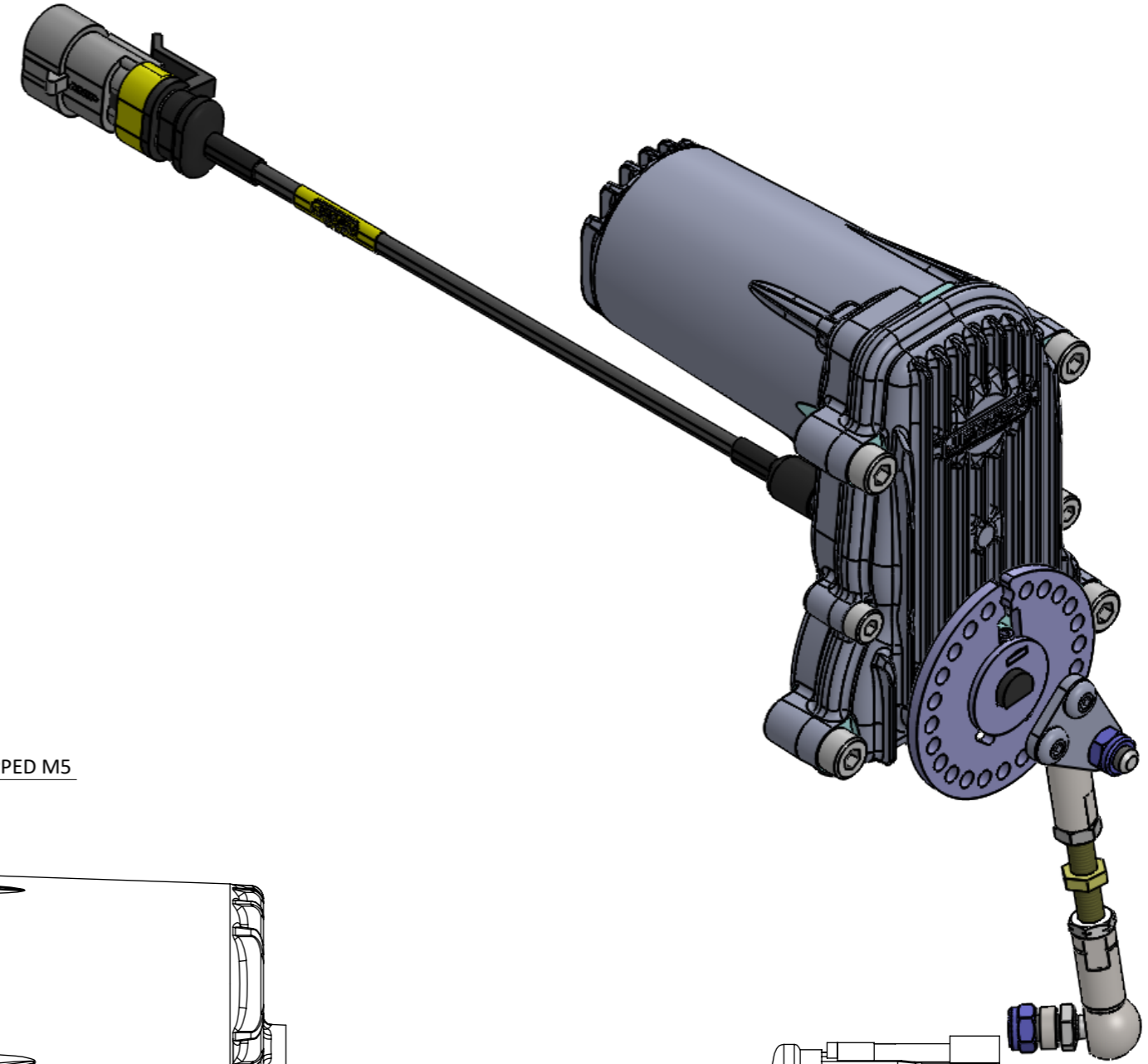

Frame: 1 of 1	
Version: 7	
Tel 01746 768810	© JENVEY DYNAMICS LTD. 2015
Web WWW.JENVEY.CO.UK	