

# SFD - SINGLE BORE THROTTLE BODY

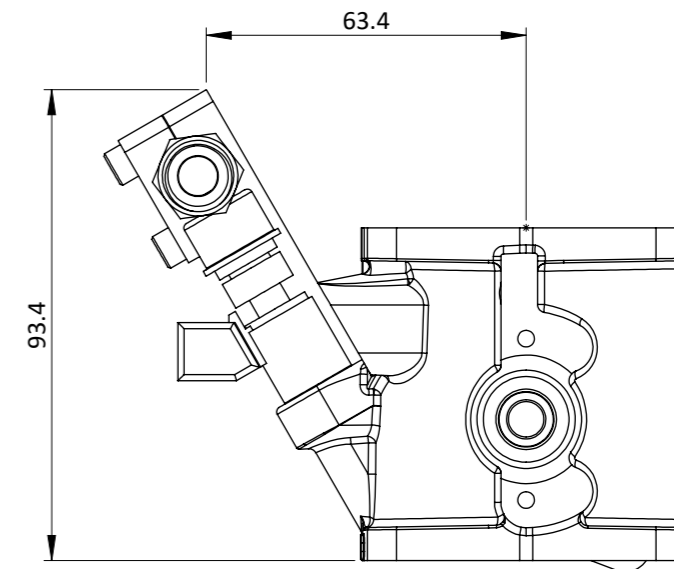

Engineered to win

BODIES WITH OUTLETS LESS THAN Ø55 COME WITH O RING GROOVE

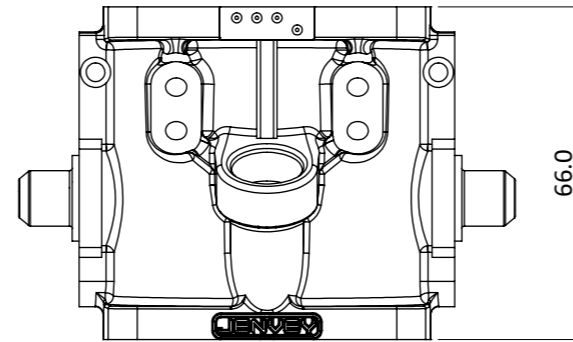
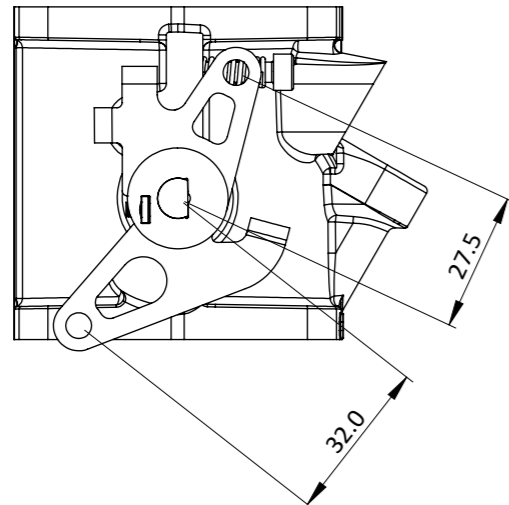
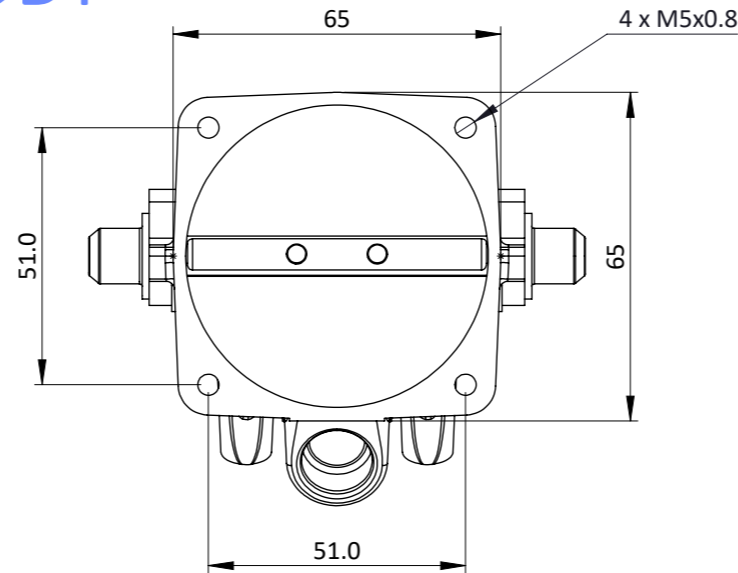
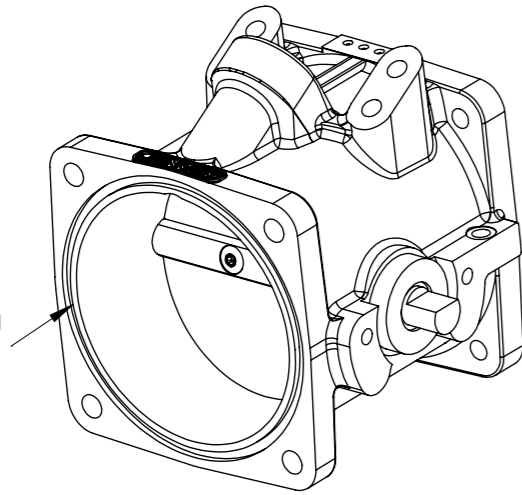

MEASUREMENTS FOR PICO INJECTOR

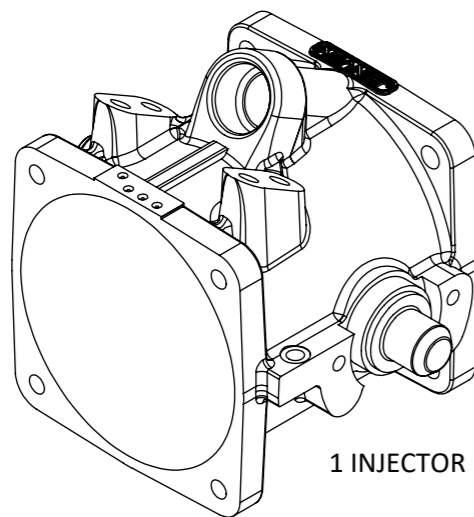

1 INJECTOR BODY

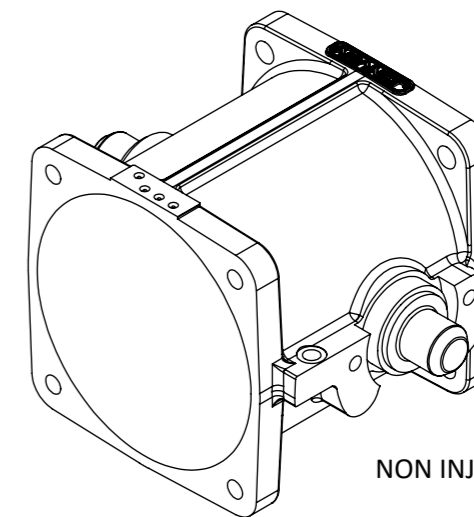
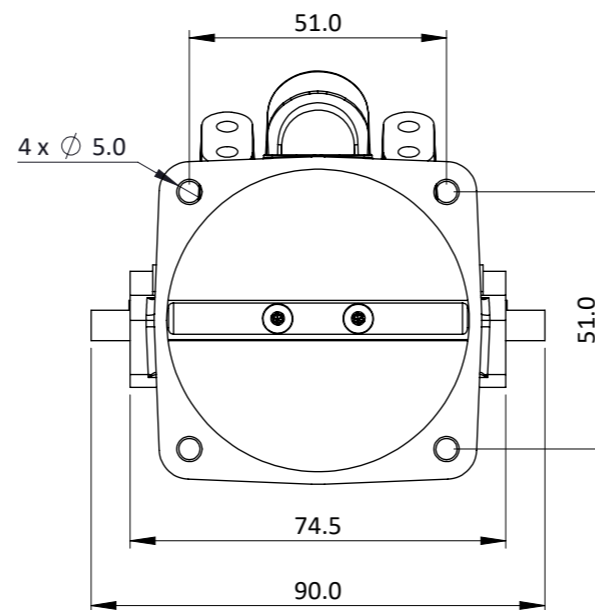

NON INJECTOR BODY

The type SFD body is the ultimate, no - compromise fuel injection throttle body. It may be fitted any way up and at centre distances of 90mm and above.

Standard sizes are; 52, 55 and 60mm whilst tapered bore bodies may be CNC bored to any reasonable shape on request.

It is available with 0 or 1 injector position. The popular sizes of suitable fuel rail are stocked, whilst others are made to order.

Complete with right hand linkage (when ordering 1 body) or standard in-line interconnecting links when ordering a number of bodies. Alternative lever configurations are available.

Bodies come with bungs for the inlet end.

Data; Spindle rotation: 82 degrees. Torque per spindle at WOT: 110 - 120 N-mm giving a tangential pull of 2.9 - 3.1 N on long arm of standard lever. Optional 310 N-mm springs available.

Other items; Quadrant throttle mechanism, linkage kits, air horns (bellmouths, trumpets, stacks), throttle potentiometers.

Frame: 1 of 1

Version: 5

Tel 01746 768810

© JENVEY DYNAMICS LTD. 2015

Web WWW.JENVEY.CO.UK

