

# TDA2 - TDA HERITAGE Ø48-50

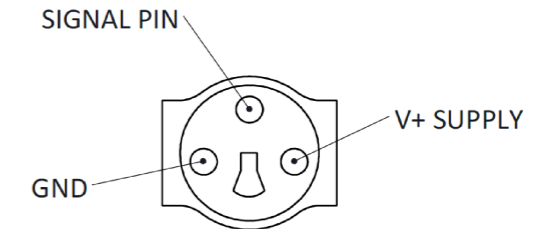

**Engineered to win**

HERITAGE THROTTLE POSITION SENSOR (TP12)  
ECONOSEAL PLUG DETAILS:



**Throttle Position Sensor  
Pin Out**

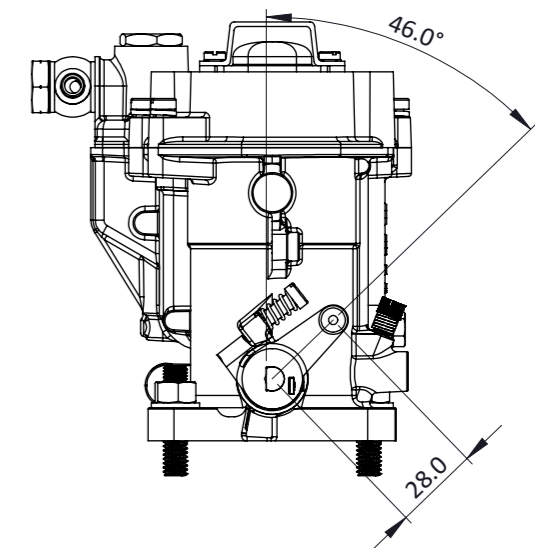

Vacuum bosses have been machined M6 on underside but do not break into bore. These can be drilled through by the customer if needed, to run IB01

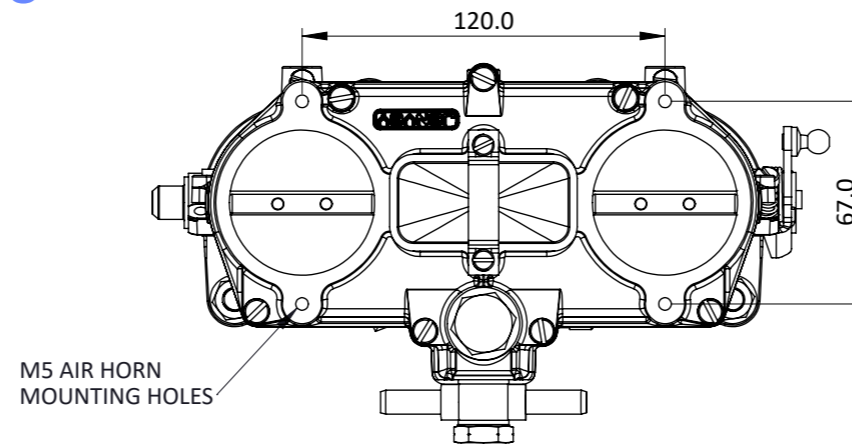
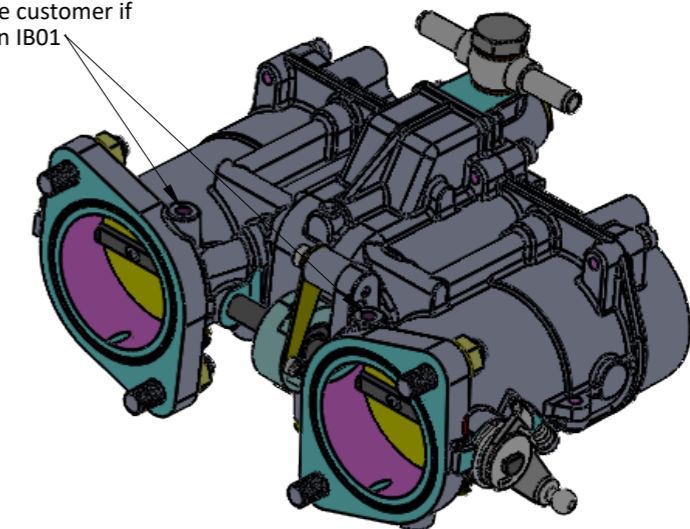

M5 AIR HORN MOUNTING HOLES

REMOVE MESH PROTECTOR BEFORE USE

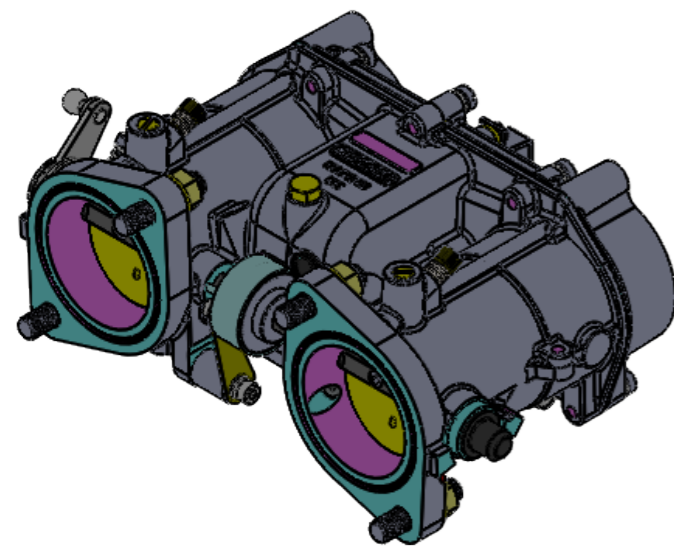
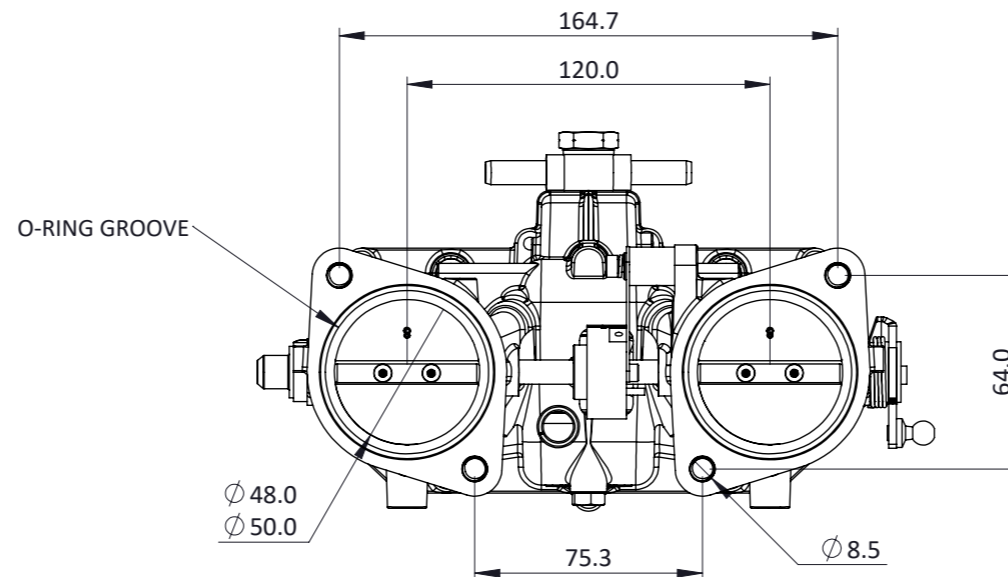
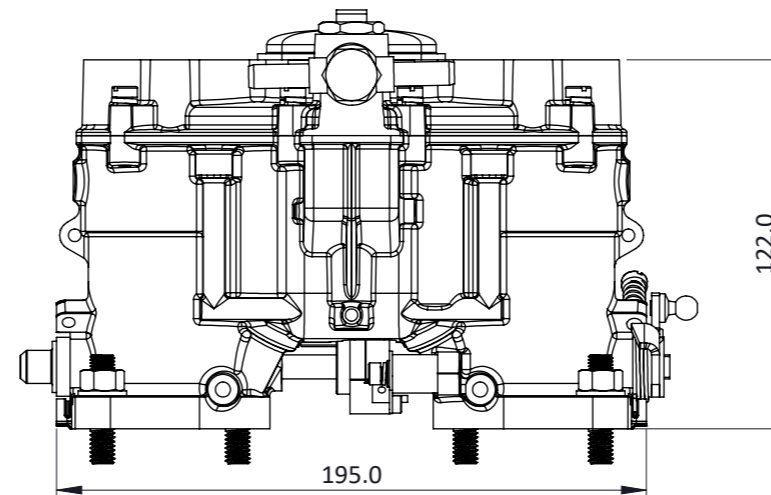
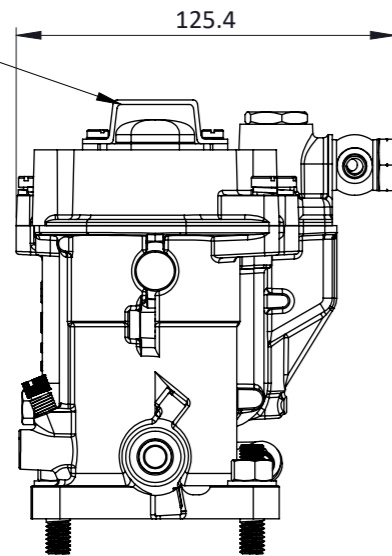

The Heritage body is designed with major dimensions identical to twin vertical carburettors from Weber, Dellorto, Solex etc. The fuel rail is integrated within the body lid, supplied with Bosch EV14 730cc/min injectors. The body comes with 'O' rings on the outlet, idle bypass adjustment, 60mm long air-horns and an internal throttle position sensor.  
Operating data; Spindle rotation: 82 degrees.

Frame: 1 of 1	
Version: 6	
Tel 01746 768810	© JENVEY DYNAMICS LTD. 2015
Web WWW.JENVEY.CO.UK	