

TDS-XX - Heritage Twin T. Body Single inc Inj, Loom, TP

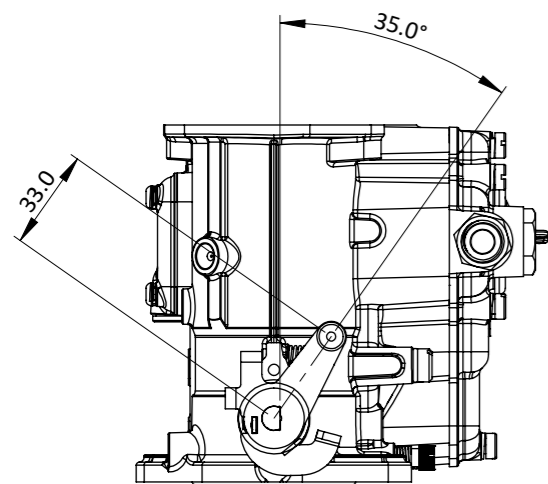

Engineered to win

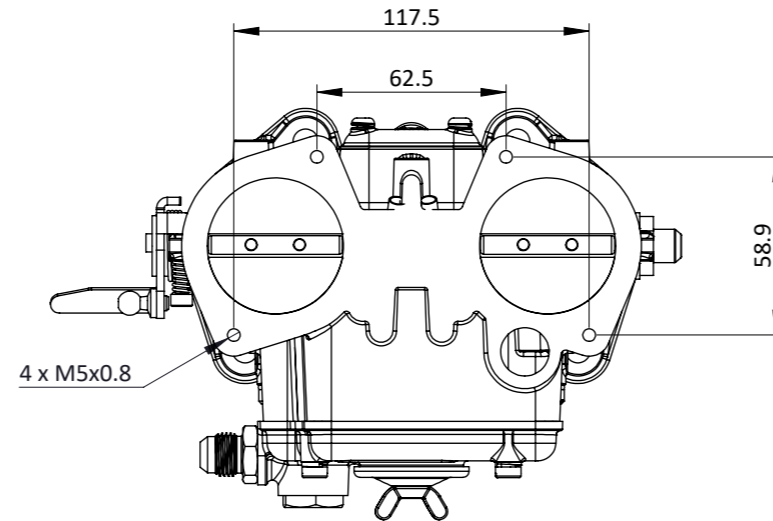
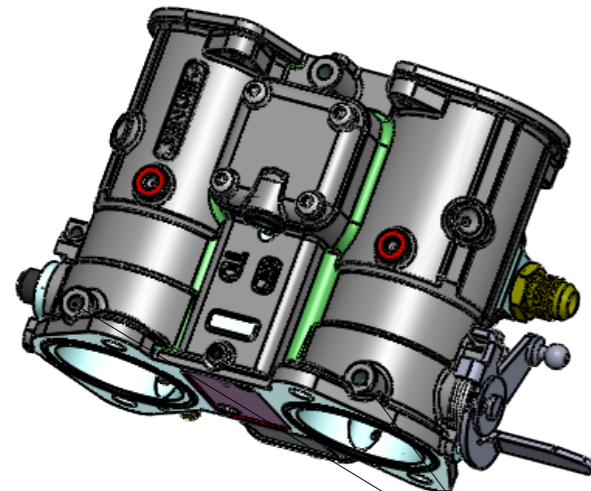

Vacuum bosses have been machined M6 on underside but do not break into bore. These can be drilled through by the customer if needed, to run IB01

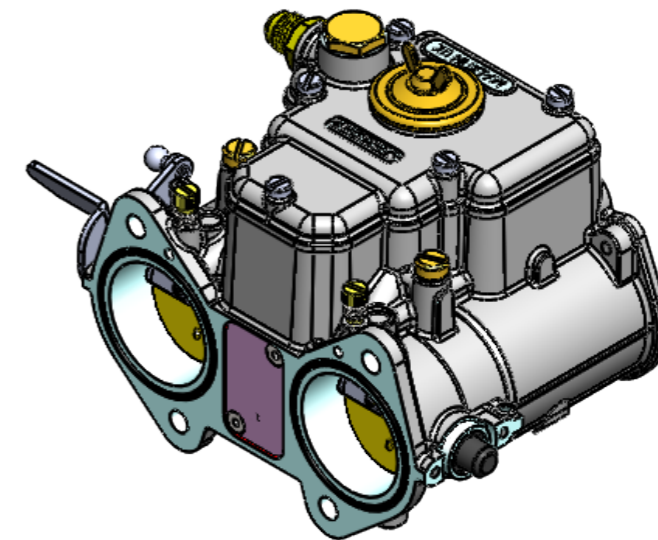
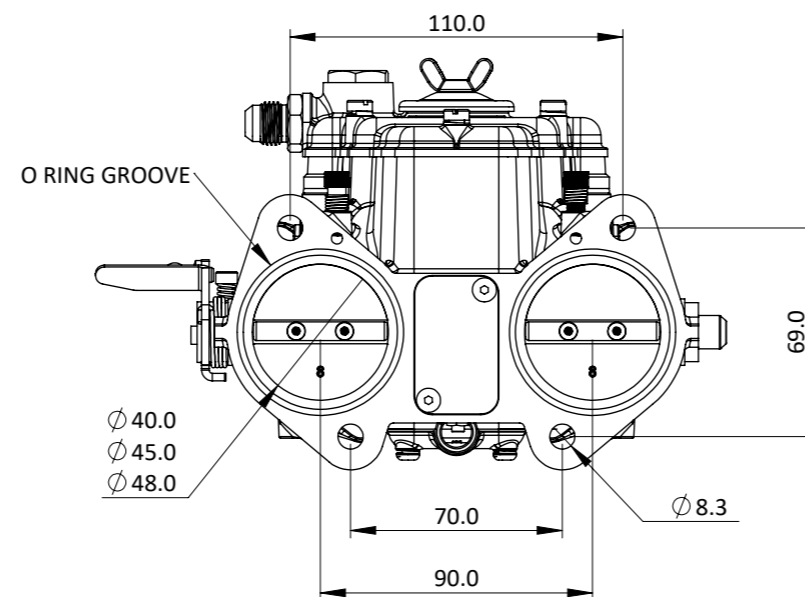
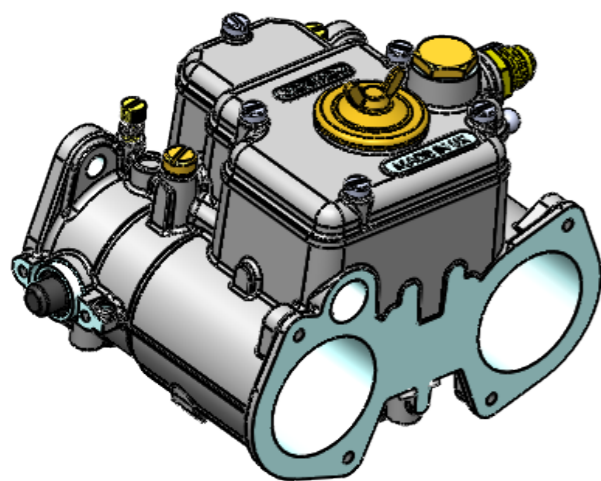
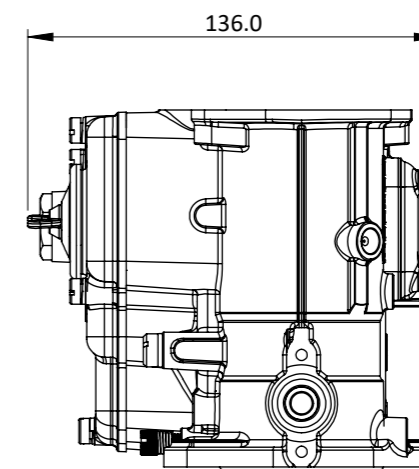
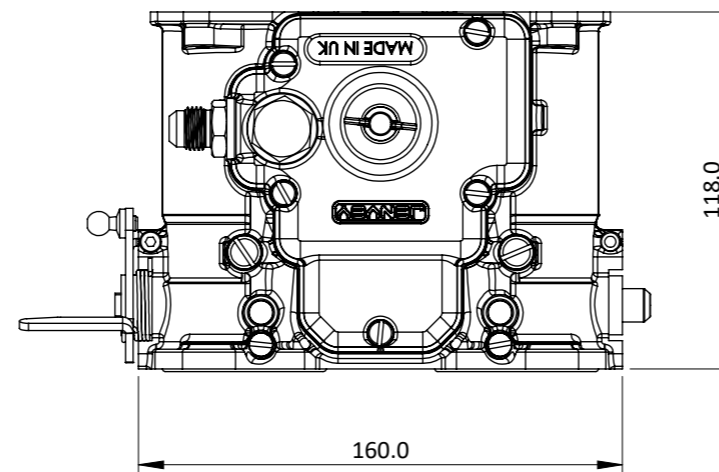

The Heritage body is designed with major dimensions identical to twin horizontal carburettors from Weber, Dellorto, Solex etc. The fuel rail is integrated within the body lid, supplied with Bosch EV14 350cc/min injectors. The body comes with 'O' rings on the outlet, idle bypass adjustment, interconnecting link and internal throttle positioning sensor. Operating data; Spindle rotation: 82 degrees.

Frame: 1 of 1

Version: 11

Tel 01746 768810

Web WWW.JENVEY.CO.UK

© JENVEY DYNAMICS LTD. 2015

